

## Quotation

To

Company :	Siemens AG	Name :	N. HOST
City / Country :	Duisburg / Germany	Dept :	Sales Dept.
Name :	Stoverink Simon	Tel :	+33 (0)3 69 20 51 50
Dept :		Fax :	+33 (0)3 88 67 60 75
Tel :		E-mail :	nhost@flender-graff.com
Fax :		Page(s) :	19
E-mail :		Copy :	
		Date :	16.03.2015

Y/ref : Khursaniyah Al Fadhili - D43-K-1801 -  
O/ref : D41104 quotation number 3

In response to your inquiry referenced above, we are pleased to confirm our quotation as follows :

### ITEM A 1 : Flender Graffenstaden (FG) High Speed increaser, model **TX50/4C**

- *Rating conditions :* Rated power at **6800 kW**  
Driven by a electric motor at **1800.0 rpm** (specified : 1800.0 rpm)  
Driving a centrifugal compressor at **7309.1 rpm** (specified : 7285.0 rpm)  
Service factor **1.45** according to **API613/03** (required : > 1.4)
- *Technical description :* Double helical  
Manufacturing according to API standard  
Flange on LS shaft end  
Flange on HS shaft end  
Estimated Weight : 4000 kg
- *Bearings description :* 2 cylindrical bearings on LS shaft  
2 offset bearings on HS shaft  
1 double acting tilting pad thrust bearing on low speed shaft non driven end
- *Mechanical running test :* Full speed, no load test during 4 hours according to the API 613 5th Edition standard.
- *Lubrication conditions :* 164 l/min of Oil ISO VG 46 at 60°C and 2.5 bar at inlet (calculated values only)
- *Miscellaneous:* Efficiency at full load : 99.03 %  
Power losses at full load : 66 kW (calculated value only)  
Anticipated Sound Pressure Level: 82.0 ± 2dB(A) at 1 meter

**Base price :** 117 900 EUR each gear box  
**Delivery time :** 36 weeks after the FG acknowledgement of the order  
**Quantity :** 8 gearboxes

# FLENDER GRAFFENSTADEN

FLENDER-GRAFFENSTADEN S.A., FRANCE  
BP 84, F-67402 ILLKIRCH-CEDEX  
1, rue du Vieux Moulin  
F-67400 ILLKIRCH-GRAFFENSTADEN

## Comments :

- Coupling data taken into account on HS Shaft:
  - o Weight: 26.6 kg
  - o Center of gravity position from shaft end: 30.9 mm
  - o Inertia: 0.266 kgm<sup>2</sup>
- Coupling data taken into account on LS Shaft:
  - o Weight: 87.5 kg
  - o Center of gravity position from shaft end: 40.9 mm
  - o Inertia: 0.875 kgm<sup>2</sup>

## Including :

- Customer witness of test
- After test disassembly and inspection
- Noise level test report
- Lateral analysis undamped
- Documentation : downloadable electronic file in english

## Instrumentation (see the complete package on additional technical data sheet):

- *Temperature package*  
12 RTD's PT100 Duplex 3 wires from Thermo Electric Company Inc.  
(2 per bearing and thrust bearing side) not wired with terminal heads..... Price included
- *Bently Nevada vibration package*  
8 radial (4 per shaft) & 2 axial (on LS shaft) vibration probes, 2 accelerometers (1 per shaft), 2 keyphasors (1 per shaft) not wired..... Price included

## Spare parts (Prices are net valid only if spares are ordered together with the gearbox):

- *Commissioning Spares*  
2 RTD's, 2 BN vibration probes, 2 BN accelerometers ..... 7 900 EUR Lot Net
- *2 Years Normal Operation Spares*  
2 set of bearings with RTD's, 1 set of oil seals ..... 48 420 EUR Lot Net
- *Strategic Spare Parts*  
One complete set of rotating elements consisting of one pinion and one gear.  
Tested if ordered together with the main gearbox according to AP1613/03  
Full Speed, No Load, with Test Report..... 51 500 EUR Lot Net
- *Container for horizontal spare rotors storage painted according FG standard*..... 17 100 EUR Lot Net

**SPECIAL PURPOSE GEAR UNITS**  
**API 613 FIFTH EDITION**  
**DATA SHEET SI UNITS**

Job No. 41104 Item No. A  
 P.O. No. \_\_\_\_\_ Date \_\_\_\_\_  
 Revision No. \_\_\_\_\_  
 Inquiry No. \_\_\_\_\_  
 Revision 1 Date 09.03.2015 By HNI  
 US Standards (1.7)  ISO Standards (1.7)

Applicable To:  Proposal  Purchase  As Built

1 For Siemens AG Duisburg  
 2 Site Khuesanlyah Al Fadhill  
 3 Unit STC-SV 08-4-A  
 4 Service EMCC  
 5 No. required 9

Manufacturer FLENDER-GRAFFENSTADEN  
 Model No. TX5014C  
 Serial No. \_\_\_\_\_  
 Driver type electric motor  
 Driven equipment centrifugal compressor

Information to be completed by purchaser

Information to be completed by manufacturer

**UNITS OF MEASUREMENT**

**BASIC GEAR DATA**

US Customary units  
 SI units

**RATING REQUIREMENTS**

Single stage  Single helical  
 Double stage  Double helical  
 Epicyclic  horizontal offset

14 Driven equip. (2.1.4): Norm. \_\_\_\_\_ Max \_\_\_\_\_ kW  
 15 Driver: Rated \_\_\_\_\_ Max \_\_\_\_\_ kW  
 16 Normal transmitted power (2.2.2) \_\_\_\_\_ kW  
 17 Gear unit rated power (2.2.1) \_\_\_\_\_ 6800 kW  
 18 Torque @ max cont speed \_\_\_\_\_ Nm  
 19 Max torque (2.2.1) \_\_\_\_\_ Nm @ \_\_\_\_\_ rpm  
 20  Reducer  Increaser  
 21 Rated speed (2.1.5): \_\_\_\_\_ rpm  
 22 Input \_\_\_\_\_ 1800 rpm  Specified  Nominal  
 23 Output \_\_\_\_\_ 7285 rpm  Specified  Nominal  
 24 Allow var in gear ratio (2.1.5) (+) (-) \_\_\_\_\_ %  
 25 Max continuous speed (1.5) \_\_\_\_\_ 1800 / 7285 rpm  
 26 Trip speed (1.5) (2.1.7) \_\_\_\_\_ 1980 / 8013.5 rpm  
 27 Gear service factor (2.2.3.1) \_\_\_\_\_ 1.4 API 613/2003 5 TH (min)  
 28 Hardness (2.2.3.2) Pinion \_\_\_\_\_ Gear \_\_\_\_\_  
 29 Shaft assembly designation (2.1.19) \_\_\_\_\_ L/R  
 30 HS shaft rot fac'g cpl'g (2.1.20.2)  CW  CCW  
 31 LS shaft rot fac'g cpl'g (2.1.20.2)  CW  CCW  
 32 External loads (2.1.16) \_\_\_\_\_  
 33 Other operating conditions (2.2.2) (2.6.1.3) \_\_\_\_\_  
 34  
 35 **INSTALLATION DATA (2.1.14)**  
 36  Indoor  Heated  Under roof  
 37  Outdoor  Unheated  Partial sides  
 38  Grade  Mezzanine  ONSHORE  
 39  Winterization required  Tropicalization required  
 40 Electrical area (2.1.10) Class \_\_\_\_\_ GIP \_\_\_\_\_ DIV \_\_\_\_\_  
 41 Electrical area (2.1.10) Zone 2 GIP IIA Temp T1 °C  
 42 Max allow SPL (2.1.6) \_\_\_\_\_ dB(A) @ \_\_\_\_\_ m  
 43 Elevation \_\_\_\_\_ m Barometer \_\_\_\_\_ kPa abs  
 44 Range of ambient temperatures: \_\_\_\_\_  
 45 \_\_\_\_\_ Dry bulb \_\_\_\_\_ Wet bulb  
 46 Normal \_\_\_\_\_ °C  
 47 Maximum \_\_\_\_\_ 82 °C  
 48 Minimum \_\_\_\_\_ 0 °C  
 49 Unusual conditions  Dust  Furnes  
 50

Mechanical rating (1.5.16) \_\_\_\_\_ 9520 kW @ 1800 / 7309.1 rpm  
 Gear service factor (2.2.3.1) \_\_\_\_\_ 1.44 API 613/2003 5 TH (actual)  
 Full load gear unit power loss \_\_\_\_\_ 66 kW  
 Gear Unit Mechanical efficiency \_\_\_\_\_ 99.03 %  
 Rating speed Pinion \_\_\_\_\_ 7,309.1 Gear \_\_\_\_\_ 1,800.0 rpm  
 Hardness used for \_\_\_\_\_  
 Rating (HB or Rc) Pinion \_\_\_\_\_ 58 HRC Gear \_\_\_\_\_ 58 HRC  
 Tooth pitting index,  $K_v$  (2.2.4.1) (2.2.4.2) \_\_\_\_\_  
 Allowable \_\_\_\_\_ 2.17 Actual \_\_\_\_\_ 2.10 MPa  
 Material index number (Fig 3, Table 4) \_\_\_\_\_ 3.03 MPa  
 Bending stress number,  $S_t$  (2.2.5.1) (2.2.5.2) \_\_\_\_\_  
 Pinion: Allowable \_\_\_\_\_ 265.4 Actual \_\_\_\_\_ 266.0 MPa  
 Gear: Allowable \_\_\_\_\_ 265.4 Actual \_\_\_\_\_ 249.9 MPa  
 Pitch line velocity \_\_\_\_\_ 77.1 m/s  
 Anticipated SPL (2.1.6) \_\_\_\_\_ 82 dB(A) @ \_\_\_\_\_ 1 m  
 $WR^2$  referred to LS shaft \_\_\_\_\_ 126.12 kgm<sup>2</sup>  
 Breakaway torque \_\_\_\_\_ 412 Nm @ LS Shaft  
 Pinion teeth hardness range \_\_\_\_\_ 58 - 63 HRC  
 Pinion teeth hardening method \_\_\_\_\_ CARBURIZED  
 HS shaft separate hardness range \_\_\_\_\_  
 Gear teeth (fin) hardness range \_\_\_\_\_ 58 - 63 HRC  
 Gear teeth hardening method \_\_\_\_\_ CARBURIZED  
 Gear hub: \_\_\_\_\_  
 Forged cylinder  Forged & Copped  Fabricated  
 Gear to Shaft fit method (2.5.3.2) \_\_\_\_\_  
 Integral  Keyed interference  Keyless interference  
 Rim attachment (2.5.3.2) \_\_\_\_\_ FORGED GEAR WHEEL  
 LS shaft hardness range \_\_\_\_\_ HB 230 - 274  
 Journal static weight loads (2.6.6.3) \_\_\_\_\_  
 Pinion \_\_\_\_\_ 128 / 42 kg Gear \_\_\_\_\_ 942 / 707 kg  
 Total gear unit assembled weight \_\_\_\_\_ 4000 kg  
 NOTES: \_\_\_\_\_  
 \_\_\_\_\_ / 11

**SPECIAL PURPOSE GEAR UNITS**  
**API 613 FIFTH EDITION**  
**DATA SHEET SI UNITS**

Job No. 41104 Item No. A  
P.O. No. \_\_\_\_\_ Date \_\_\_\_\_  
Requisition No. \_\_\_\_\_  
Inquiry No. \_\_\_\_\_  
Revision 1 Date 06.03.2015 By HNI

■ GEAR DATA				○ COUPLINGS AND GUARDS		
	Pinion	Gear		Pinion	Gear	
Number of teeth	33	134	Coupling furnished by (3.2.1)	Compr. Supplier	Compr. Supplier	
Gear ratio	4,06		Mount coupling halves (3.2.2)	Compr. Supplier	Compr. Supplier	
Tangential load, "Wt" (2.2.4.2)	88.155	N	Cplg. guard adapter by (3.2.3)	Gear Supplier	Gear Supplier	
AGMA Geometry factor "J"	0,55	0,57	Cplg. guard furnished by (3.2.3)	Compr. Supplier	Compr. Supplier	
Pitch diameter	201,56	818,44	Coupling vendor (3.2.3)			
Outside diameter	214,10	827,60	Vendor's model number (3.2.3)			
Root diameter	187,25	800,74	Coupling weight on shaft, kg	26,6	87,5	
Center groove diameter	177,00	790,00	CG inboard / outboard of shaft end	Outboard	Outboard	
Normal pressure angle	20,00	deg	Hub drill template provided	<input type="checkbox"/>	<input type="checkbox"/>	
Normal diametral pitch	4,62	in <sup>-1</sup>	■ SHAFT END DETAIL (2.5.4.2)			
Helix angle	25,00	deg	Shaft end detail specified by: <input checked="" type="radio"/> Purchaser <input type="radio"/> Gear vendor			
Center distance	510,00	mm	(Integral unless otherwise specified)			
Backlash min	0,34	mm	Shaft end detail if 'otherwise' specified:			
Net face width, "Fw"	260,00	mm	Tapered / Keyless	<input type="radio"/> Pinion <input type="radio"/> Gear	<input type="radio"/> Pinion <input type="radio"/> Gear	
Pinion L/D	1,71		Tapered / 1-Key	<input type="radio"/> Pinion <input type="radio"/> Gear	<input type="radio"/> Pinion <input type="radio"/> Gear	
Face overlap ratio	6,36		Tapered / 2-Keys	<input type="radio"/> Pinion <input type="radio"/> Gear	<input type="radio"/> Pinion <input type="radio"/> Gear	
Transverse contact ratio	1,45		Cylindrical / 1-Key	<input type="radio"/> Pinion <input type="radio"/> Gear	<input type="radio"/> Pinion <input type="radio"/> Gear	
AGMA 6011 service factor	2,64		Cylindrical / 2-Keys	<input type="radio"/> Pinion <input type="radio"/> Gear	<input type="radio"/> Pinion <input type="radio"/> Gear	
Rating based on ANSIVAGMA 6011 with SF=1.0			Other <u>Flanged</u>	<input checked="" type="radio"/> Pinion <input type="radio"/> Gear	<input checked="" type="radio"/> Pinion <input type="radio"/> Gear	
Durability Power	21442	kW	Shaft diameter	120,0	190,0 mm	
Strength Power	17946	kW	(if integral flange use diameter immediately adjacent to flange)			
Tooth Surface Finish, Ra	0,4	µm	■ RADIAL BEARINGS			
Tooth Generation Process	Hobbling	Hobbling	Type	Pinion	Gear	
Tooth Finishing Process	Grinding	Grinding		OFFSET / OFFSET	CYL. / CYL.	
Lead modification (2.2.4.6)	<input checked="" type="radio"/> Not Req'd	<input type="radio"/> Req'd	Diameter	130 / 130	200 / 200 mm	
Calculated Total Lead Mismatch		µm	Length	130 / 130	100 / 100 mm	
■ SCUFFING DATA (2.2.6)			Journal velocity	49,8 / 49,8	18,8 / 18,8 m/s	
Scuffing Data per ANSIVAGMA 926-A03			Loading	2,78 / 2,81	2,87 / 2,71 N/mm²	
Scuffing Risk (2.2.6) <u>&lt;=5% (Low)</u>	Calculation Method	AGMA925	Clearance (min-max)		mm	
Composite surface roughness, σx	0,57	µm	Span	550	550 mm	
Specific film thickness, EHL λmin	3,31	µm	Power loss each bearing	13,8 / 13,8	3,0 / 3,0 kW	
Tooth temperature, θm	82	°C	Oil flow each bearing	42,0 / 42,0	10,0 / 10,0 l/min	
Maximum contact temperature, θBmax	101	°C	■ THRUST BEARINGS			
■ MATERIALS			Location	OPP.CPLG.SIDE		
Gear casing	Steel	Oil seals	aluminum	Manufacturer	FLENDER	
Pinion(s)	18CrNiMo7-6			Type	NO	
Gear rim(s)	18CrNiMo7-6			Size	COMB.TAP.LANDS	
HS Shaft	Integral	LS Shaft	42CrMo4	Area	11615 mm²	
Radial bearings	Babbitt	Backing	Steel	Loading	1,14 MPa	
Thrust bearing(s)	Babbitt	Backing	Steel	Rating	1,50 MPa	
○ SHAFT END DETAIL			Int. thrust load		N	
<input checked="" type="checkbox"/> Gear shaft end for coupling integral flange (2.5.4.2)			Ext. thrust load	4.050	9.200 N	
<input checked="" type="checkbox"/> Pinion shaft end for coupling integral flange (2.5.4.2)			Power loss each	0,0	6,0 kW	
<input checked="" type="checkbox"/> Other : <u>WITHOUT BOLTS</u>			Oil flow each bearing	0,0	20,0 l/min	
			NOTES :			

**SPECIAL PURPOSE GEAR UNITS**  
**API 613 FIFTH EDITION**  
**DATA SHEET SI UNITS**

Job No. 41104 Item No. A  
P.O. No. \_\_\_\_\_ Date \_\_\_\_\_  
Requisition No. \_\_\_\_\_  
Inquiry No. \_\_\_\_\_  
Revision 1 Date 06.03.2015 By HNI

1	<b>○ LUBRICATION REQUIREMENTS</b>	<b>○ ADDITIONAL REQUIREMENTS</b>																								
2	<input type="checkbox"/> Oil system furnished by (2.8.3) _____	<b>○ VIBRATION DETECTORS</b>																								
3	<input type="checkbox"/> Other _____ <input type="checkbox"/> Gear vendor																									
4	<input type="checkbox"/> Oil visc. _____ cp @ 40°C _____ cp @ 100°C (2.8.6)																									
5	<input type="checkbox"/> ISO Grade _____ Load stage (2.2.6) <u>5,0</u>																									
6																										
7	<b>■ MESH</b>																									
8	Mesh and windage power loss <u>26,4</u> kW	<b>RADIAL</b> (3.4.2.1) (2.7.4.5) (2.7.4.6)																								
9	Oil flow, mesh <u>40,0</u> l/min	<input checked="" type="checkbox"/> Manufacturer <u>BENTLY NEVADA</u> <input checked="" type="checkbox"/> Total No. <u>8</u>																								
10		<input checked="" type="checkbox"/> X-Y probes pinion bearings <input checked="" type="checkbox"/> Coupling end <input checked="" type="checkbox"/> Blind end																								
11	<b>■ LUBRICATION REQUIREMENTS</b>	<input checked="" type="checkbox"/> X-Y probes gear bearings <input checked="" type="checkbox"/> Coupling end <input checked="" type="checkbox"/> Blind end																								
12	Min. startup oil temperature <u>20,0</u> °C	<input type="checkbox"/> Other _____																								
13	Normal oil inlet temperature <u>60,0</u> °C	<b>AXIAL</b> (3.4.2.1) (2.7.4.5) (2.7.4.6)																								
14	Maximum oil inlet temperature <u>65,0</u> °C	<input checked="" type="checkbox"/> Manufacturer <u>BENTLY NEVADA</u> <input checked="" type="checkbox"/> Total No. <u>2</u>																								
15	Unit oil flow (total) <u>164,0</u> l/min	<input type="checkbox"/> Dual probes at each thrust bearing																								
16	Unit oil pressure <u>2,5</u> bar	<input type="checkbox"/> Single probe any shaft without thrust bearing																								
17	<input type="checkbox"/> Oil visc. _____ cp @ 40°C _____ cp @ 100°C (2.8.6)	<input type="checkbox"/> Other _____																								
18	<input type="checkbox"/> ISO Grade <u>46</u> Load stage (2.2.6) <u>5,0</u>	<b>ONE EVENT PER REVOLUTION PROBE</b> (2.7.4.5) (2.7.4.6)																								
19		<input checked="" type="checkbox"/> Manufacturer <u>BENTLY NEVADA</u> Total No. <u>2</u>																								
20	<b>■ PIPING CONNECTIONS</b>	<input checked="" type="checkbox"/> One on input shaft <input checked="" type="checkbox"/> One on output shaft																								
21	<table border="1" style="width:100%; border-collapse: collapse;"> <thead> <tr> <th>Service</th> <th>No.</th> <th>Size</th> <th>Type</th> </tr> </thead> <tbody> <tr> <td>Lube oil inlet</td> <td>1</td> <td>2 in.</td> <td>ANSI 150 LBS</td> </tr> <tr> <td>Lube oil outlet</td> <td>1</td> <td>6 in.</td> <td>ANSI 150 LBS</td> </tr> <tr> <td>Casing drain *</td> <td></td> <td></td> <td></td> </tr> <tr> <td>Vent</td> <td>1</td> <td>1,5 in.</td> <td>ANSI 150 LBS</td> </tr> <tr> <td>Casing purge</td> <td></td> <td></td> <td></td> </tr> </tbody> </table>	Service	No.	Size	Type	Lube oil inlet	1	2 in.	ANSI 150 LBS	Lube oil outlet	1	6 in.	ANSI 150 LBS	Casing drain *				Vent	1	1,5 in.	ANSI 150 LBS	Casing purge				<input type="checkbox"/> Other _____
Service	No.	Size	Type																							
Lube oil inlet	1	2 in.	ANSI 150 LBS																							
Lube oil outlet	1	6 in.	ANSI 150 LBS																							
Casing drain *																										
Vent	1	1,5 in.	ANSI 150 LBS																							
Casing purge																										
22		<b>ACCELEROMETER</b> (3.4.2.1) (2.7.4.5) (2.7.4.6)																								
23		<input checked="" type="checkbox"/> Manufacturer <u>BENTLY NEVADA</u> <input checked="" type="checkbox"/> No. required <u>2</u>																								
24		<input checked="" type="checkbox"/> Pinion coupling end <input checked="" type="checkbox"/> Gear coupling end																								
25		<input type="checkbox"/> Other _____																								
26		<b>○ TEMPERATURE DETECTORS</b>																								
27	* Casing drain is 'dead bottom' housing drain, not lube oil outlet	<input type="checkbox"/> Dial type thermometers (3.4.2.7) _____																								
28	<b>○ MOUNTING PLATES</b>	<input checked="" type="checkbox"/> Type brg. temp. sensors (3.4.2.7) (2.7.1.3) <u>PT100</u>																								
29	<input type="checkbox"/> Gear furnished with (3.3.1.1)	<input type="checkbox"/> RTD <input type="checkbox"/> Thermocouple / <input type="checkbox"/> Simplex <input checked="" type="checkbox"/> Duplex																								
30	<input type="checkbox"/> Baseplate <input type="checkbox"/> Soleplate <input type="checkbox"/> Subplate(s) (3.3.2.10)	Calibration <u>Yes</u>																								
31	<input type="checkbox"/> Mounting plates(s) furnished by (3.3.1.1) _____	<input checked="" type="checkbox"/> HSAS bearings no. sensors each <u>2</u> / <u>2</u>																								
32	<input type="checkbox"/> Baseplate leveling (3.3.2.3) _____	<input checked="" type="checkbox"/> Thrust number of sensing elements each face <u>2</u>																								
33	<input type="checkbox"/> Baseplate with leveling pads (3.3.2.3)																									
34	<input type="checkbox"/> Baseplate suitable for column mounting (3.3.2.4)	<b>○ OTHER VIBRATION AND TEMPERATURE</b>																								
35	<input type="checkbox"/> Vendor review of purchaser's foundation dwgs. (2.1.13)	(3.4.2.5) (3.4.2.6) Other Gear vendor																								
36	<input type="checkbox"/> Grout type (3.3.1.2.4) _____	Oscillator demodulator supplied by <input type="checkbox"/> <input checked="" type="checkbox"/>																								
37		Vibration monitor supplied by <input checked="" type="checkbox"/> <input type="checkbox"/>																								
38	<b>○ CONTRACT DATA</b>	<input type="checkbox"/> Vibration shutdown delay time _____ seconds																								
39	<input type="checkbox"/> Test data prior to shipment _____	Temperature monitor supplied by <input checked="" type="checkbox"/> <input type="checkbox"/>																								
40	<input checked="" type="checkbox"/> Progress report (5.3.3) _____	Oscillator demodulator J-box by <input checked="" type="checkbox"/> <input type="checkbox"/>																								
41	<input type="checkbox"/> Vendor signoff of inspector checklist (4.1.1.3)	Temp. sensor termination J-box by <input checked="" type="checkbox"/> <input type="checkbox"/>																								
42	<input checked="" type="checkbox"/> Information retained for 20 years (4.2.1.1) (4.2.2.6.1)	J-box type _____ Mount _____																								
43	<input type="checkbox"/> Technical manual (5.3.5.4)	<b>○ MISCELLANEOUS</b>																								
44	<input checked="" type="checkbox"/> PAINTING (4.4.3.1) <input checked="" type="checkbox"/> <u>Flender standard RAL5015 (blue)</u>	<input checked="" type="checkbox"/> Undamped critical analysis report (2.6.2.1)																								
45	<input checked="" type="checkbox"/> Painting housing interior not allowed (2.3.1.14)	<input type="checkbox"/> w/ dampd rotr respsn analys rpt (2.6.2.4.3) (2.6.2.6)																								
46	<b>○ SHIPMENT</b>	Torsional analysis by (2.6.5.2) <input type="checkbox"/> Gear vendor <input checked="" type="checkbox"/> Other																								
47	<input type="checkbox"/> Steel rotor storage container (4.4.5) <input type="checkbox"/> Shaft covers (4.4.4)	<input type="checkbox"/> Spare set of gear rotors (4.3.2.4)																								
48	Contract unit Spares	<input type="checkbox"/> Gear case furnished with inlet purge connection (2.4.3)																								
49	Export boxing <input type="checkbox"/> <input type="checkbox"/>	<input type="checkbox"/> Orientation of oil inlet & drain conns. (2.4.6) _____																								
50	Domestic boxing <input type="checkbox"/> <input type="checkbox"/>	<input checked="" type="checkbox"/> Filter breather location (2.3.1.12) <u>Prov. on upper casing</u>																								
51	Outdoor storage over 6 mos. <input type="checkbox"/> 3 years indoor <input type="checkbox"/> (4.4.3.8)	<input type="checkbox"/> Torsional device provisions (2.5.4.5) _____																								
		<input type="checkbox"/> Rotor vertical storage provisions (2.5.4.8) _____																								
		<input type="checkbox"/> Rotor vertical storage fixture(s) (3.6.2) _____																								
		<input type="checkbox"/> Vendor service rep. on site (2.1.13)																								

**SPECIAL PURPOSE GEAR UNITS  
API 613 FIFTH EDITION  
DATA SHEET SI UNITS**

Job No. 41104 Item No. A  
P.O. No. \_\_\_\_\_ Date \_\_\_\_\_  
Requisition No. \_\_\_\_\_  
Inquiry No. \_\_\_\_\_  
Revision 1 Date 06.03.2015 By HNI

O INSPECTIONS AND TESTS (4.1)				
<input type="checkbox"/> Advance notice of witness testing required (4.1.3)				
Number calendar days _____				
	Req'd	Witness	Observe	Test Log
6	Shop Inspection (4.1.1)	<input type="checkbox"/>	<input type="checkbox"/>	<input type="checkbox"/>
7	Cleanliness Inspection (4.2.3.1)	<input type="checkbox"/>	<input type="checkbox"/>	<input type="checkbox"/>
8	Hardness Verification (4.2.3.3)	<input checked="" type="checkbox"/>	<input type="checkbox"/>	<input checked="" type="checkbox"/>
9	Dismantle-reassembly (4.3.2.3.1)	<input checked="" type="checkbox"/>	<input type="checkbox"/>	<input type="checkbox"/>
10	Contact Check (2.5.2.2)	<input checked="" type="checkbox"/>	<input type="checkbox"/>	<input type="checkbox"/>
11	Contact Check Tape Lift (2.5.2.2)	<input checked="" type="checkbox"/>	<input type="checkbox"/>	<input checked="" type="checkbox"/>
12	Gear accuracy check (2.5.2.1)	<input checked="" type="checkbox"/>	<input type="checkbox"/>	<input type="checkbox"/>
13	Double helical axial stability (2.5.2.3)	<input checked="" type="checkbox"/>	<input type="checkbox"/>	<input checked="" type="checkbox"/>
14	Special testing Integral forged gears (2.5.3.3)			
15	(testing per mutual agreement)	<input type="checkbox"/>	<input type="checkbox"/>	<input type="checkbox"/>
16	Residual unbalance check (2.6.6.2)	<input checked="" type="checkbox"/>	<input type="checkbox"/>	<input checked="" type="checkbox"/>
17	Mechanical Run Test (Main) (4.3.2)	<input checked="" type="checkbox"/>	<input type="checkbox"/>	<input checked="" type="checkbox"/>
18	Mechanical Run Test (Spare) (4.3.2.4)	<input type="checkbox"/>	<input type="checkbox"/>	<input type="checkbox"/>
19	Addl. Mechanical Tests (4.3.2.2.16)	<input type="checkbox"/>	<input type="checkbox"/>	<input type="checkbox"/>
20	Part or Full Load And Full Speed			
21	Test (4.3.3.1)	<input type="checkbox"/>	<input type="checkbox"/>	<input type="checkbox"/>
22	Full torque, reduced speed (4.3.3.2)	<input type="checkbox"/>	<input type="checkbox"/>	<input type="checkbox"/>
23	Full Torque Static Test (4.3.3.3)	<input type="checkbox"/>	<input type="checkbox"/>	<input type="checkbox"/>
24	Back-To-Back Locked Torque			
25	Test (4.3.3.4)	<input type="checkbox"/>	<input type="checkbox"/>	<input type="checkbox"/>
26	Sound Level Test (4.3.3.5)	<input checked="" type="checkbox"/>	<input type="checkbox"/>	<input checked="" type="checkbox"/>
27	Additional gear tooth test (4.2.2.8)	<input type="checkbox"/>	<input type="checkbox"/>	<input type="checkbox"/>
28	Use shop Lube System	<input checked="" type="checkbox"/>	<input type="checkbox"/>	<input type="checkbox"/>
29	Use job lube system	<input type="checkbox"/>	<input type="checkbox"/>	<input type="checkbox"/>
30	Use shop Vibration Probes, Etc.	<input type="checkbox"/>	<input type="checkbox"/>	<input type="checkbox"/>
31	Use job Vibration Probes, Etc.	<input checked="" type="checkbox"/>	<input type="checkbox"/>	<input type="checkbox"/>
32	Final Assembly, Maintenance &			
33	Running Clearance (4.2.1.1.e)	<input checked="" type="checkbox"/>	<input type="checkbox"/>	<input checked="" type="checkbox"/>
34	Oil System Cleanliness (4.2.3.2)	<input type="checkbox"/>	<input type="checkbox"/>	<input type="checkbox"/>
35	Oil System-Casing Joint			
36	Tightness (4.3.2.1.4)	<input type="checkbox"/>	<input type="checkbox"/>	<input type="checkbox"/>
37	Warning And Protection			
38	Devices (4.3.2.1.5)	<input type="checkbox"/>	<input type="checkbox"/>	<input type="checkbox"/>
39	Seismic Vibration Data (4.3.2.2.3)	<input type="checkbox"/>	<input type="checkbox"/>	<input type="checkbox"/>
40	Vibration, Phase Plots (4.3.2.2.12)	<input checked="" type="checkbox"/>	<input type="checkbox"/>	<input checked="" type="checkbox"/>
41	Oil inlet Range test (4.3.2.2.13)	<input type="checkbox"/>	<input type="checkbox"/>	<input type="checkbox"/>
42	Tape recorded Vibration Data	<input checked="" type="checkbox"/>	<input type="checkbox"/>	<input checked="" type="checkbox"/>
43	(4.3.2.2.14) (4.3.2.2.15)	<input type="checkbox"/>	<input type="checkbox"/>	<input type="checkbox"/>
Purchaser copy				
44	NON-DESTRUCTIVE TESTING (4.2.1.2) (4.2.2.1)			
	Surface	Sub surface		Log
46	<input type="checkbox"/> Casing	<input type="checkbox"/>	<input type="checkbox"/>	<input type="checkbox"/>
47	<input checked="" type="checkbox"/> Rot. Elmts.	<input checked="" type="checkbox"/>	<input checked="" type="checkbox"/>	<input checked="" type="checkbox"/>
48	<input checked="" type="checkbox"/> Bearings	<input checked="" type="checkbox"/>	<input checked="" type="checkbox"/>	<input checked="" type="checkbox"/>
49	<input type="checkbox"/> Other :	<input type="checkbox"/>	<input type="checkbox"/>	<input type="checkbox"/>
50	(Specify)			

NOTES : \_\_\_\_\_

**During start-up, gears can exhibit a transient spike reading of vibration levels that will exceed shutdown settings. Therefore a trip multiplier is recommended in the control system.**

**Mechanical running test duration 4 hours including**

- Shaft vibration record using job vibration probes if ordered
- Bearings temperature records
- Casing vibration measurement
- Sound level pressure measurement
- Power losses measurement at oil outlet
- Performed with oil ISO VG 32

**Oil flow requirement and power losses are calculated values only, add normal safety margins for sizing heat exchangers.**

**PRELIMINARY MASS ELASTIC DATA**

Customer : Siemens AG Duisburg  
 Destination : Khursariyah Al Fadhili  
 Purchaser order :  
 F-G job number : D 41104A1 OL  
 Type and serial N° : TX50/4C

Power rating : 6800 kW  
 Service factor : AP1613/03  $\geq 1,4$   
 Input speed : 1800 rpm  
 Output speed : 7309,1 rpm  
 Speed ratio : 4,06

Weight HSS : 143,5 kg  
 Weight pos. from teeth middle HSS : 63,4 mm  
 Inertia HSS : 0,585 Kg.m<sup>2</sup>  
 Stiffness HSS : 5,916 MN/m/rad  
 Bearing type 1 : Offset 130 x 130  
 Bearing type 2 : Offset 130 x 130  
 Add. weight on brg. side 1 : 26,6 kg

Weight LSS : 1561,2 kg  
 Weight pos. from teeth middle LSS : 10,5 mm  
 Inertia LSS : 116,473 Kg.m<sup>2</sup>  
 Stiffness LSS : 39,014 MN/m/rad  
 Bearing type 4 : Cylindrical 200 x 100  
 Bearing type 3 : Cylindrical 200 x 100  
 Add. weight on brg. side 4 : 87,5 kg

Positive direction of external

APPAREIL.xls \_ Edition du :06.03.2015  
 1/1

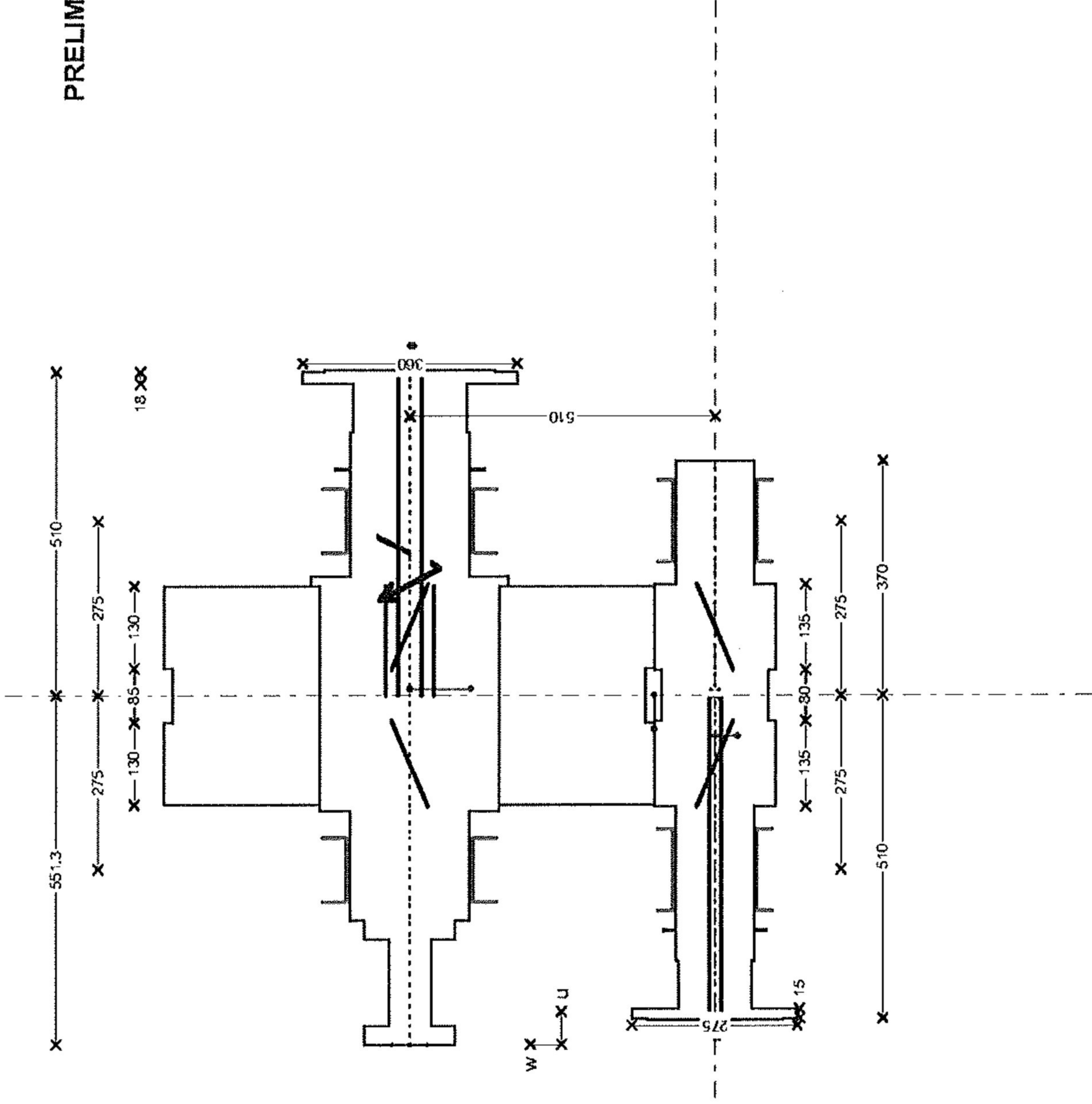

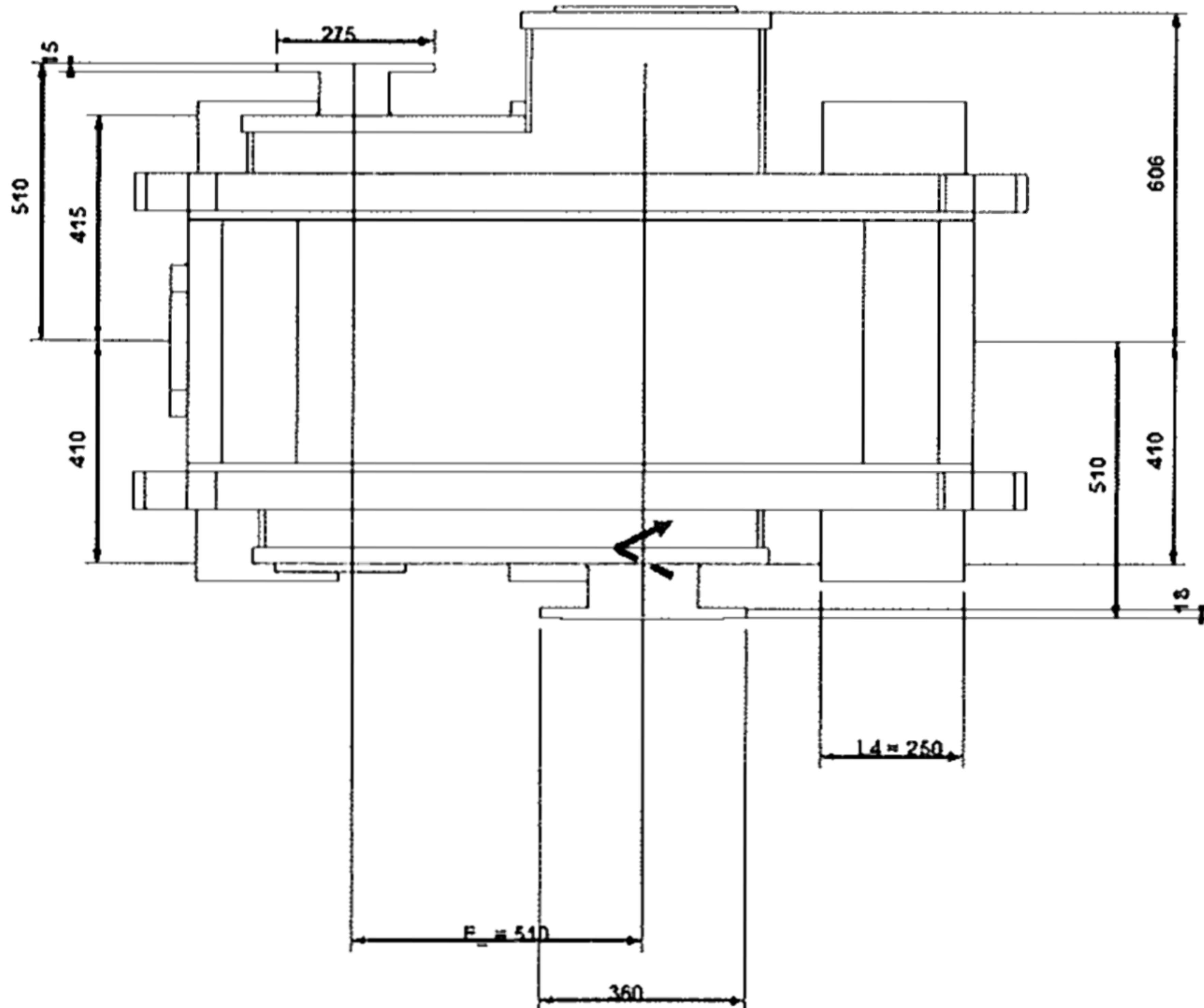
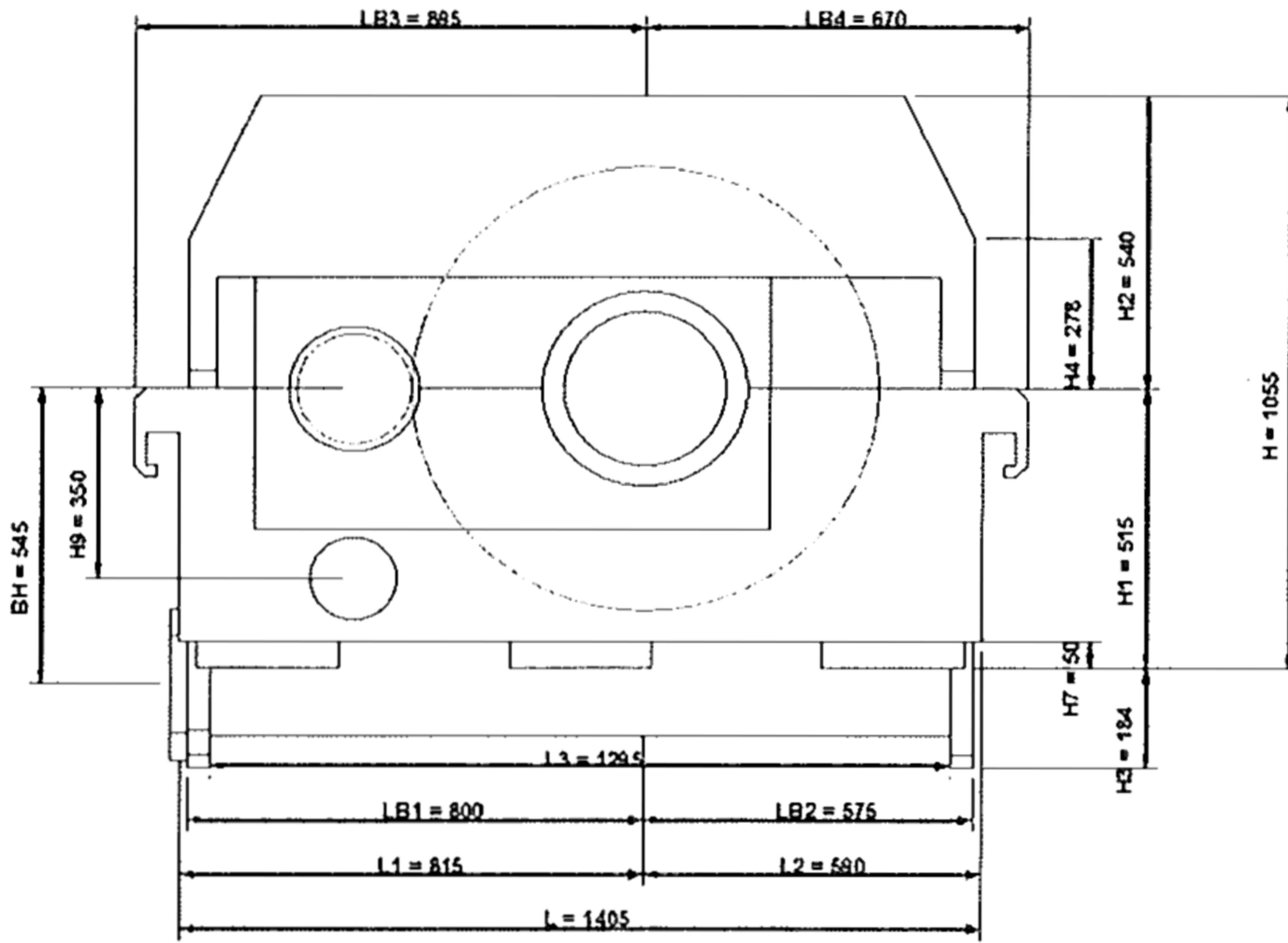



<b>ADDITIONAL TECHNICAL DATASHEET</b>		Job No. <u>41104</u> Item No. <u>A</u>																																			
		P.O. No. _____ Date _____																																			
		Requisition No. _____																																			
		Inquiry No. _____																																			
		Revision <u>1</u> Date <u>06.03.2016</u> By <u>HNI</u>																																			
<input checked="" type="checkbox"/> <b>ADDITIONAL GEAR DATA</b>		<input type="checkbox"/> <b>TURNING GEAR (Dimensioning is preliminary !)</b>																																			
<b>Efficiency</b>		<b>Calculation results</b>																																			
<table border="1" style="width:100%; border-collapse: collapse;"> <thead> <tr> <th>Percent of rated power</th> <th>Efficiency</th> </tr> </thead> <tbody> <tr> <td style="text-align: center;">100%</td> <td style="text-align: center;">99,03</td> </tr> <tr> <td style="text-align: center;">75%</td> <td style="text-align: center;">98,92</td> </tr> <tr> <td style="text-align: center;">50%</td> <td style="text-align: center;">98,79</td> </tr> <tr> <td style="text-align: center;">25%</td> <td style="text-align: center;">98,08</td> </tr> <tr> <td style="text-align: center;">10%</td> <td style="text-align: center;">90,80</td> </tr> </tbody> </table>		Percent of rated power	Efficiency	100%	99,03	75%	98,92	50%	98,79	25%	98,08	10%	90,80	Required turning speed _____ rpm Actual turning speed _____ rpm Required breakaway torque _____ Nm Actual breakaway torque _____ Nm Actual maximum torque _____ Nm Actual acceleration time _____ s																							
Percent of rated power	Efficiency																																				
100%	99,03																																				
75%	98,92																																				
50%	98,79																																				
25%	98,08																																				
10%	90,80																																				
<b>Losses</b>		<b>Motor</b>																																			
Power loss at no load _____ kW Heat rejection _____ kcal/h		Supplier _____ Power _____ kW Voltage _____ V Frequency _____ Hz Speed _____ rpm Electric standard _____																																			
<input type="checkbox"/> <b>PUMP DETAILS (Dimensioning is preliminary !)</b>																																					
Design : _____ Speed : _____ rpm Oil flow : _____ l/min Oil pressure : _____ bar NPSH : _____ m Safety valve : _____ Driving method : _____ Material : _____ Flanges : _____ Testing : _____ Furniture of ATEX certificate : _____		<b>Turning gear</b> Type _____ Ratio _____  <b>Clutch</b> Type _____ Max. allowable torque _____ Nm  <b>Miscellaneous</b> Starting device _____ Switch details _____																																			
<input checked="" type="checkbox"/> <b>INSTRUMENTATION PACKAGE</b>																																					
<b>Thermometer</b>		<b>Thermoelements</b>																																			
<table border="1" style="width:100%; border-collapse: collapse;"> <thead> <tr> <th></th> <th>Bearing</th> <th>Thrust bearing</th> <th>Oil inlet/outlet</th> </tr> </thead> <tbody> <tr> <td>Qty</td> <td></td> <td></td> <td></td> </tr> <tr> <td>Type</td> <td></td> <td></td> <td></td> </tr> </tbody> </table>			Bearing	Thrust bearing	Oil inlet/outlet	Qty				Type				<table border="1" style="width:100%; border-collapse: collapse;"> <thead> <tr> <th></th> <th>Bearing</th> <th>Thrust bearing</th> <th>Oil inlet/outlet</th> </tr> </thead> <tbody> <tr> <td>Type</td> <td>DUPLEX 2x3F</td> <td>DUPLEX 2x3F</td> <td></td> </tr> <tr> <td>Classification</td> <td>IEC60751</td> <td>IEC60751</td> <td></td> </tr> <tr> <td>Removable from the outside</td> <td>NO</td> <td>NO</td> <td></td> </tr> <tr> <td>ATEX</td> <td>ATEX Eexia</td> <td>ATEX Eexia</td> <td></td> </tr> </tbody> </table>		Bearing	Thrust bearing	Oil inlet/outlet	Type	DUPLEX 2x3F	DUPLEX 2x3F		Classification	IEC60751	IEC60751		Removable from the outside	NO	NO		ATEX	ATEX Eexia	ATEX Eexia				
	Bearing	Thrust bearing	Oil inlet/outlet																																		
Qty																																					
Type																																					
	Bearing	Thrust bearing	Oil inlet/outlet																																		
Type	DUPLEX 2x3F	DUPLEX 2x3F																																			
Classification	IEC60751	IEC60751																																			
Removable from the outside	NO	NO																																			
ATEX	ATEX Eexia	ATEX Eexia																																			
<b>Shaft vibrations</b>																																					
<table border="1" style="width:100%; border-collapse: collapse;"> <thead> <tr> <th></th> <th>Radial</th> <th>Axial</th> <th>Keyphasor</th> <th>Accelerometer</th> </tr> </thead> <tbody> <tr> <td>Type</td> <td>B N. 3300 XL 8mm Sys 9M</td> <td>HS No LS BENTLY NEVADA 3300 XL 8mm Sys 9M</td> <td>B N. 3300 XL 8mm Sys 9M</td> <td>ACCELEROMETER BENTLY</td> </tr> <tr> <td>Probe</td> <td>Yes</td> <td>HS No LS Yes</td> <td>Yes</td> <td></td> </tr> <tr> <td>Proximitior</td> <td>Yes</td> <td>HS No LS Yes</td> <td>Yes</td> <td style="background-color: #cccccc;"></td> </tr> <tr> <td>Probe holder</td> <td>Yes</td> <td>HS No LS Yes</td> <td>Yes</td> <td style="background-color: #cccccc;"></td> </tr> <tr> <td>Connection head</td> <td>Yes</td> <td>HS No LS Yes</td> <td>Yes</td> <td style="background-color: #cccccc;"></td> </tr> <tr> <td>mounting kit</td> <td style="background-color: #cccccc;"></td> <td style="background-color: #cccccc;"></td> <td style="background-color: #cccccc;"></td> <td>Yes</td> </tr> </tbody> </table>				Radial	Axial	Keyphasor	Accelerometer	Type	B N. 3300 XL 8mm Sys 9M	HS No LS BENTLY NEVADA 3300 XL 8mm Sys 9M	B N. 3300 XL 8mm Sys 9M	ACCELEROMETER BENTLY	Probe	Yes	HS No LS Yes	Yes		Proximitior	Yes	HS No LS Yes	Yes		Probe holder	Yes	HS No LS Yes	Yes		Connection head	Yes	HS No LS Yes	Yes		mounting kit				Yes
	Radial	Axial	Keyphasor	Accelerometer																																	
Type	B N. 3300 XL 8mm Sys 9M	HS No LS BENTLY NEVADA 3300 XL 8mm Sys 9M	B N. 3300 XL 8mm Sys 9M	ACCELEROMETER BENTLY																																	
Probe	Yes	HS No LS Yes	Yes																																		
Proximitior	Yes	HS No LS Yes	Yes																																		
Probe holder	Yes	HS No LS Yes	Yes																																		
Connection head	Yes	HS No LS Yes	Yes																																		
mounting kit				Yes																																	
<b>Junction box(es)</b>		<b>Miscellaneous</b>																																			
Qty _____ Manufacturer _____ Material _____ ATEX _____ None		Identification <input checked="" type="checkbox"/> wire <input checked="" type="checkbox"/> conduit <input type="checkbox"/> junction box Conduit type _____ Transmitter type _____ Qty _____ Terminal block type _____ Qty _____																																			

# FLENDER GRAFFENSTADEN

FLENDER-GRAFFENSTADEN S.A., FRANCE  
BP 84, F-67402 ILLKIRCH-CEDEX  
1, rue du Vieux Moulin  
F-67400 ILLKIRCH-GRAFFENSTADEN

Y/ref : Khursaniyah Al Fadhili - D43-K-3801 -  
O/ref : D41104 quotation number 3

## ITEM B 1 : Flender Graffenstaden (FG) High Speed increaser, model **TX40/5C**

### - Rating conditions :

Rated power at **1620 kW**  
Driven by a electric motor at **1800.0 rpm** (specified : 1800.0 rpm)  
Driving a centrifugal compressor at **10737.9 rpm** (specified : 10736.0 rpm)  
Service factor **1.47** according to **API613/03** (required : > 1.4)

### - Technical description :

Double helical  
Manufacturing according to API standard  
Flange on LS shaft end  
Flange on HS shaft end  
Estimated Weight : 1900 kg

### - Bearings description :

2 cylindrical bearings on LS shaft  
2 tilting pads bearings on HS shaft  
1 double acting tilting pad thrust bearing on low speed shaft non driven end

- *Mechanical running test* : Full speed, no load test during 4 hours according to the API 613 5th Edition standard.

### - Lubrication conditions :

64 l/min of Oil ISO VG 46 at 60°C and 2.5 bar at inlet (calculated values only)

### - Miscellaneous:

Efficiency at full load : 98.70 %  
Power losses at full load : 21 kW (calculated value only)  
Anticipated Sound Pressure Level: 82.0 ± 2dB(A) at 1 meter

**Base price : 103 850 EUR** each gear box

**Delivery time : 36 weeks** after the FG acknowledgement of the order

**Quantity : 1 gearbox**

### Comments :

- Coupling data taken into account on HS Shaft:
  - o Weight: 10.4 Kg
  - o Center of gravity position from shaft end: 28.2 mm
  - o Inertia: 0.104 kgm<sup>2</sup>
- Coupling data taken into account on LS Shaft:
  - o Weight: 26.4 Kg
  - o Center of gravity position from shaft end: 30.9 mm
  - o Inertia: 0.264 kgm<sup>2</sup>

### Including :

- Customer witness of test
- After test disassembly and inspection
- Noise level test report
- Lateral analysis undamped
- Documentation : downloadable electronic file in English

### Instrumentation (see the complete package on additional technical data sheet):

- *Temperature package*
  - 12 RTD's PT100 Duplex 3 wires from Thermo Electric Company Inc.  
(2 per bearing and thrust bearing side) not wired with terminal heads..... Price included
- *Bently Nevada vibration package*
  - 8 radial (4 per shaft) & 2 axial (on LS shaft) vibration probes, 2 accelerometers (1 per shaft), 2 keyphasors (1 per shaft) not wired ..... Price included

### Spare parts (Prices are net valid only if spares are ordered together with the gearbox):

- *Commissioning Spares*
  - 2 RTD's, 2 BN vibration probes, 2 BN accelerometers ..... 7 900 EUR Lot Net
- *2 Years Normal Operation Spares*
  - 1 set of bearings with RTD's, 1 set of oil seals ..... 26 010 EUR Lot Net
- *Strategic Spare Parts*
  - One complete set of rotating elements consisting of one pinion and one gear.  
Tested if ordered together with the main gearbox according to API613/03  
Full Speed, No Load, with Test Report..... 37 100 EUR Lot Net
- *Container for horizontal spare rotors storage painted according FG standard*..... 15 850 EUR Lot Net

**SPECIAL PURPOSE GEAR UNITS**  
**API 613 FIFTH EDITION**  
**DATA SHEET SI UNITS**

Job No. 41104 Item No. B  
 P.O. No. \_\_\_\_\_ Date \_\_\_\_\_  
 Requisition No. \_\_\_\_\_  
 Inquiry No. \_\_\_\_\_  
 Revision 1 Date 06.03.2015 By HNI

1 Applicable To:  Proposal  Purchase  As Built  
 2 For Siemens AG Duisburg Manufacturer FLENDER-GRAFFENSTADEN  
 3 Site Khursaniyah Al Fadhili Model No. TX40/5C  
 4 Unit STC-SV 06-3-A Serial No. \_\_\_\_\_  
 5 Service EM/CC Driver type electric motor  
 6 No. required 1 Driven equipment centrifugal compressor

**NOTE : Numbers within ( ) refer to applicable API standard 613 paragraphs**

Information To be completed by purchaser

Information to be completed by manufacturer

**UNITS OF MEASUREMENT**

US Customary units  
 SI units

**RATING REQUIREMENTS**

14 Driven equip. (2.1.4): Norm. \_\_\_\_\_ Max \_\_\_\_\_ kW  
 15 Driver: Rated \_\_\_\_\_ Max \_\_\_\_\_ kW  
 16 Normal transmitted power (2.2.2) \_\_\_\_\_ kW  
 17 Gear unit rated power (2.2.1) 1620 kW  
 18 Torque @ max cont speed \_\_\_\_\_ Nm  
 19 Max torque (2.2.1) \_\_\_\_\_ Nm @ \_\_\_\_\_ rpm  
 Reducer  Increaser  
 21 Rated speed (2.1.5):  
 22 Input 1800 rpm  Specified  Nominal  
 23 Output 10736 rpm  Specified  Nominal  
 24 Allow var in gear ratio (2.1.5) (+) (-) \_\_\_\_\_ %  
 25 Max continuous speed (1.5) 1800 / 10736 rpm  
 26 Trip speed (1.5) (2.1.7) 1980 / 11809,6 rpm  
 27 Gear service factor (2.2.3.1) 1,4 API 613/2003 5 TH (min)  
 28 Hardness (2.2.3.2) Pinion \_\_\_\_\_ Gear \_\_\_\_\_  
 29 Shaft assembly designation (2.1.19) L/R  
 30 HS shaft rot fac'g cpl'g (2.1.20.2)  CW  CCW  
 31 LS shaft rot fac'g cpl'g (2.1.20.2)  CW  CCW  
 32 External loads (2.1.16) \_\_\_\_\_  
 33 Other operating conditions (2.2.2) (2.6.1.3) \_\_\_\_\_

**INSTALLATION DATA (2.1.14)**

Indoor  Heated  Under roof  
 Outdoor  Unheated  Partial sides  
 Grade  Mezzanine  **ONSHORE**  
 Winterization required  Tropicalization required

40 Electrical area (2.1.10) Class \_\_\_\_\_ Grp \_\_\_\_\_ Div \_\_\_\_\_  
 41 Electrical area (2.1.10) Zone 2 Grp IIA Temp T1 °C  
 42 Max allow SPL (2.1.6) \_\_\_\_\_ dB(A) @ \_\_\_\_\_ m  
 43 Elevation \_\_\_\_\_ m Barometer \_\_\_\_\_ kPa abs  
 44 Range of ambient temperatures:  
 45 Dry bulb \_\_\_\_\_ Wet bulb \_\_\_\_\_  
 46 Normal \_\_\_\_\_ °C \_\_\_\_\_ °C  
 47 Maximum 82 °C \_\_\_\_\_ °C  
 48 Minimum 0 °C \_\_\_\_\_ °C  
 49 Unusual conditions  Dust  Fumes

**BASIC GEAR DATA**

Single stage  Single helical  
 Double stage  Double helical  
 Epicyclic  horizontal offset

Mechanical rating (1.5.16) 2268 kW @ 1800 / 10737,9 rpm  
 Gear service factor (2.2.3.1) 1,46 API 613/2003 5 TH (actual)  
 Full load gear unit power loss 21 kW  
 Gear Unit Mechanical efficiency 98,70 %  
 Rating speed Pinion 10.737,9 Gear 1.800,0 rpm  
 Hardness used for  
 Rating, (HB or Rc) Pinion 58 HRC Gear 58 HRC  
 Tooth pitting index, "K" (2.2.4.1) (2.2.4.2)  
 Allowable 2,17 Actual 2,06 MPa  
 Material index number (Fig 3, Table 4) 3,03 MPa  
 Bending stress number, "S<sub>t</sub>" (2.2.5.1) (2.2.5.2)  
 Pinion: Allowable 265,4 Actual 251,0 MPa  
 Gear: Allowable 265,4 Actual 238,8 MPa  
 Pitch line velocity 63,0 m/s  
 Anticipated SPL (2.1.6) 82 dB(A) @ 1 m  
 WR<sup>2</sup> referred to LS shaft 29,88 kgm<sup>2</sup>  
 Breakaway torque 90 Nm @ LS Shaft  
 Pinion teeth hardness range 58 - 63 HRC  
 Pinion teeth hardening method CARBURIZED  
 HS shaft separate hardness range \_\_\_\_\_  
 Gear teeth (rim) hardness range 58 - 63 HRC  
 Gear teeth hardening method CARBURIZED  
 Gear hub:  
 Forged cylinder  Forged & Copied  Fabricated  
 Gear to Shaft fit method (2.5.3.2)  
 Integral  Keyed interference  Keyless interference  
 Rim attachment (2.5.3.2) FORGED GEAR WHEEL  
 LS shaft hardness range HB 230 - 274  
 Journal static weight loads (2.6.6.3)  
 Pinion 37 / 4 kg Gear 347 / 253 kg  
 Total gear unit assembled weight 1900 kg  
 NOTES: \_\_\_\_\_  
 \_\_\_\_\_  
 \_\_\_\_\_

**SPECIAL PURPOSE GEAR UNITS**  
**API 613 FIFTH EDITION**  
**DATA SHEET SI UNITS**

Job No.	41104	Item No.	B
P.O. No.		Date	
Requisition No.			
Inquiry No.			
Revision	1	Date	06.03.2015 By HNI

○ COUPLINGS AND GUARDS		
	Pinion	Gear
Coupling furnished by (3.2.1)	Compr. Supplier	Compr. Supplier
Mount coupling halves (3.2.2)	Compr. Supplier	Compr. Supplier
Cplg. guard adapter by (3.2.3)	Gear Supplier	Gear Supplier
Cplg. guard furnished by (3.2.3)	Compr. Supplier	Compr. Supplier
Coupling vendor (3.2.3)		
Vendor's model number (3.2.3)		
Coupling weight on shaft, kg	10,4	26,4
CG Inboard / outboard of shaft end	Outboard	Outboard
Hub drill template provided	<input type="checkbox"/>	<input type="checkbox"/>

■ SHAFT END DETAIL (2.5.4.2)		
Shaft end detail specified by:	<input checked="" type="radio"/> Purchaser <input type="radio"/> Gear vendor	
(Integral unless otherwise specified)		
Shaft end detail if 'otherwise' specified:	Pinion	Gear
Tapered / Keyless	<input type="radio"/> <input type="checkbox"/>	<input type="radio"/> <input type="checkbox"/>
Tapered / 1-Key	<input type="radio"/> <input type="checkbox"/>	<input type="radio"/> <input type="checkbox"/>
Tapered / 2-Keys	<input type="radio"/> <input type="checkbox"/>	<input type="radio"/> <input type="checkbox"/>
Cylindrical / 1-Key	<input type="radio"/> <input type="checkbox"/>	<input type="radio"/> <input type="checkbox"/>
Cylindrical / 2-Keys	<input type="radio"/> <input type="checkbox"/>	<input type="radio"/> <input type="checkbox"/>
Other <u>Flanged</u>	<input checked="" type="radio"/> <input type="checkbox"/>	<input checked="" type="radio"/> <input type="checkbox"/>
Shaft diameter	75,0	120,0 mm
(If integral flange use diameter immediately adjacent to flange)		

■ RADIAL BEARINGS		
Type	Pinion	Gear
Diameter	80 / 80	120 / 120 mm
Length	56 / 56	60 / 60 mm
Journal velocity	45,0 / 45,0	11,3 / 11,3 m/s
Loading	3,08 / 3,10	2,52 / 2,26 N/mm <sup>2</sup>
Clearance (min-max)		
Span	340	340 mm
Power loss each bearing	6,3 / 6,3	0,7 / 0,7 kW
Oil flow each bearing	15,0 / 15,0	5,0 / 5,0 l/min

■ THRUST BEARINGS		
Location		OPP.CPLG.SIDE
Manufacturer	FLENDER	FLENDER
Type	NO	COMB.TAP.LANDS
Size		BPK LEG 4"
Area		5160 mm <sup>2</sup>
Loading		1,35 MPa
Rating		1,50 MPa
Int. thrust load		N
Ext. thrust load	2.700	4.250 N
Power loss each	0,0	5,0 kW
Oil flow each bearing	0,0	15,0 l/min

NOTES:

■ GEAR DATA			
	Pinion	Gear	
Number of teeth	29	173	
Gear ratio	5,97		
Tangential load, *Wt* (2.2.4.2)	25.731		N
AGMA Geometry factor *J*	0,52	0,54	
Pitch diameter	111,98	668,02	mm
Outside diameter	120,30	673,50	mm
Root diameter	103,05	656,32	mm
Center groove diameter	93,00	640,00	mm
Normal pressure angle	20,00		deg
Normal diametral pitch	7,26		in <sup>-1</sup>
Helix angle	24,25		deg
Center distance	390,00		mm
Backlash min	0,28		mm
Net face width, *Fw*	130,00		mm
Pinion L/D	1,74		
Face overlap ratio	4,86		
Transverse contact ratio	1,45		
AGMA 6011 service factor	2,87		
Rating based on ANSI/AGMA 6011 with SF=1.0			
Durability Power	5404		kW
Strength Power	4652		kW
Tooth Surface Finish, Ra	0,4	0,4	µm
Tooth Generation Process	Hobbing	Hobbing	
Tooth Finishing Process	Grinding	Grinding	
Lead modification (2.2.4.6)	<input checked="" type="radio"/> Not Req'd	<input type="radio"/> Req'd	
Calculated Total Lead Mismatch			µm
■ SCUFFING DATA (2.2.6)			
Scuffing Data per ANSI/AGMA 925-A03			
Scuffing Risk (2.2.6) <=5% (Low)	Calculation Method		AGMA925
Composite surface roughness, ox	0,57		µm
Specific film thickness, EHL λmin	2,54		µm
Tooth temperature, θm	80		°C
Maximum contact temperature, θBmax	93		°C
■ MATERIALS			
Gear casing	Steel	Oil seals	aluminium
Pinion(s)	18CrNiMo7-6		
Gear rim(s)	18CrNiMo7-6		
HS Shaft	Integral	LS Shaft	42CrMo4
Radial bearings	Babbitt	Backing	Steel
Thrust bearing(s)	Babbitt	Backing	Steel
○ SHAFT END DETAIL			
<input type="checkbox"/> Gear shaft end for coupling integral flange (2.5.4.2)			
<input checked="" type="checkbox"/> Pinion shaft end for coupling integral flange (2.5.4.2)			
<input checked="" type="checkbox"/> Other: WITHOUT BOLTS			

**SPECIAL PURPOSE GEAR UNITS**  
**API 613 FIFTH EDITION**  
**DATA SHEET SI UNITS**

Job No. 41104 Item No. B  
 P.O. No. \_\_\_\_\_ Date \_\_\_\_\_  
 Requisition No. \_\_\_\_\_  
 Inquiry No. \_\_\_\_\_  
 Revision 1 Date 06.03.2015 By HNI

1 **○ LUBRICATION REQUIREMENTS**

2  Oil system furnished by (2.8.3) \_\_\_\_\_

3  Other \_\_\_\_\_  Gear vendor \_\_\_\_\_

4  Oil visc. \_\_\_\_\_ cp @ 40°C \_\_\_\_\_ cp @ 100°C (2.8.6)

5  ISO Grade \_\_\_\_\_ Load stage (2.2.6) 7,0

6

7 **■ MESH**

8 Mesh and windage power loss 2,0 kW

9 Oil flow, mesh 9,0 l/min

10

11 **■ LUBRICATION REQUIREMENTS**

12 Min. startup oil temperature 20,0 °C

13 Normal oil inlet temperature 60,0 °C

14 Maximum oil inlet temperature 65,0 °C

15 Unit oil flow (total) 64,0 l/min

16 Unit oil pressure 2,5 bar

17  Oil visc. \_\_\_\_\_ cp @ 40°C \_\_\_\_\_ cp @ 100°C (2.8.6)

18  ISO Grade 46 Load stage (2.2.6) 7,0

19

20 **■ PIPING CONNECTIONS**

Service	No.	Size	Type
Lube oil inlet	1	1,5 in.	ANSI 150 LBS
Lube oil outlet	1	6 in.	ANSI 150 LBS
Casing drain *			
Vent	1	1,5 in.	ANSI 150 LBS
Casing purge			

27 \* Casing drain is 'dead bottom' housing drain, not lube oil outlet

28 **○ MOUNTING PLATES**

29  Gear furnished with (3.3.1.1)

30  Baseplate  Soleplate  Subplate(s) (3.3.2.10)

31  Mounting plates(s) furnished by (3.3.1.1) \_\_\_\_\_

32  Baseplate leveling (3.3.2.3) \_\_\_\_\_

33  Baseplate with leveling pads (3.3.2.3)

34  Baseplate suitable for column mounting (3.3.2.4)

35  Vendor review of purchaser's foundation dwgs. (2.1.13)

36  Grou type (3.3.1.2.4) \_\_\_\_\_

37

38 **○ CONTRACT DATA**

39  Test data prior to shipment \_\_\_\_\_

40  Progress report (5.3.3) \_\_\_\_\_

41  Vendor signoff of inspector checklist (4.1.1.3)

42  Information retained for 20 years (4.2.1.1) (4.2.2.6.1)

43  Technical manual (5.3.5.4)

44  PAINTING (4.4.3.1)  Flender standard RAL5015 (blue)

45  Painting housing interior not allowed (2.3.1.14)

46 **○ SHIPMENT**

47  Steel rotor storage container (4.4.5)  Shaft covers (4.4.4)

	Contract unit	Spares
Export boxing	<input type="checkbox"/>	<input type="checkbox"/>
Domestic boxing	<input type="checkbox"/>	<input type="checkbox"/>
Outdoor storage over 6 mos.	<input type="checkbox"/>	3 years indoor <input type="checkbox"/> (4.4.3.9)

1 **○ ADDITIONAL REQUIREMENTS**

2 **○ VIBRATION DETECTORS**

**RADIAL (3.4.2.1) (2.7.4.5) (2.7.4.6)**

Manufacturer BENTLY NEVADA  Total No. 8

X-Y probes pinion bearings  Coupling end  Blind end

X-Y probes gear bearings  Coupling end  Blind end

Other \_\_\_\_\_

**AXIAL (3.4.2.1) (2.7.4.5) (2.7.4.6)**

Manufacturer BENTLY NEVADA  Total No. 2

Dual probes at each thrust bearing

Single probe any shaft without thrust bearing

Other \_\_\_\_\_

**ONE EVENT PER REVOLUTION PROBE (2.7.4.5) (2.7.4.6)**

Manufacturer BENTLY NEVADA Total No. 2

One on input shaft  One on output shaft

Other \_\_\_\_\_

**ACCELEROMETER (3.4.2.1) (2.7.4.5) (2.7.4.6)**

Manufacturer BENTLY NEVADA  No. required 2

Pinion coupling end  Gear coupling end

Other \_\_\_\_\_

3 **○ TEMPERATURE DETECTORS**

Dial type thermometers (3.4.2.7) \_\_\_\_\_

Type brg. temp. sensors (3.4.2.7) (2.7.1.3) PT100

RTD  Thermocouple /  Simplex  Duplex

Calibration Yes

HSAS bearings no. sensors each 2 / 2

Thrust number of sensing elements each face 2

4 **○ OTHER VIBRATION AND TEMPERATURE**

(3.4.2.5) (3.4.2.6) Other Gear vendor

Oscillator demodulator supplied by

Vibration monitor supplied by

Vibration shutdown delay time \_\_\_\_\_ seconds

Temperature monitor supplied by

Oscillator demodulator J-box by

Temp. sensor termination J-box by

J-box type \_\_\_\_\_ Mount \_\_\_\_\_

5 **○ MISCELLANEOUS**

Undamped critical analysis report (2.6.2.1)

w/ dampd rotr respsn analys rpt (2.6.2.4.3) (2.6.2.6)

Torsional analysis by (2.6.5.2)  Gear vendor  Other

Spare set of gear rotors (4.3.2.4)

Gear case furnished with inlet purge connection (2.4.3)

Orientation of oil inlet & drain conns. (2.4.6) \_\_\_\_\_

Filter breather location (2.3.1.12) Prov. on upper casing

Torsional device provisions (2.5.4.5) \_\_\_\_\_

Rotor vertical storage provisions (2.5.4.8) \_\_\_\_\_

Rotor vertical storage fixture(s) (3.6.2) \_\_\_\_\_

Vendor service rep. on site (2.1.13)

**SPECIAL PURPOSE GEAR UNITS  
API 613 FIFTH EDITION  
DATA SHEET SI UNITS**

Job No.	41104	Item No.	B
P.O. No.		Date	
Requisition No.			
Inquiry No.			
Revision	1	Date	06.03.2015
		By	HNI

O INSPECTIONS AND TESTS (4.1)				
	Req'd	Witness	Observe	Test Log
1 <input type="checkbox"/> Advance notice of witness testing required (4.1.3)				
2 Number calendar days _____				
3				
4				
5 Shop Inspection (4.1.1)	<input type="checkbox"/>	<input type="checkbox"/>	<input type="checkbox"/>	
6 Cleanliness Inspection (4.2.3.1)	<input type="checkbox"/>	<input type="checkbox"/>	<input type="checkbox"/>	
7 Hardness Verification (4.2.3.3)	<input checked="" type="checkbox"/>	<input type="checkbox"/>	<input type="checkbox"/>	<input checked="" type="checkbox"/>
8 Dismantle-reassembly (4.3.2.3.1)	<input checked="" type="checkbox"/>	<input type="checkbox"/>	<input type="checkbox"/>	<input type="checkbox"/>
9 Contact Check (2.5.2.2)	<input checked="" type="checkbox"/>	<input type="checkbox"/>	<input type="checkbox"/>	<input type="checkbox"/>
10 Contact Check Tape Lift (2.5.2.2)	<input checked="" type="checkbox"/>	<input type="checkbox"/>	<input type="checkbox"/>	<input checked="" type="checkbox"/>
11 Gear accuracy check (2.5.2.1)	<input checked="" type="checkbox"/>	<input type="checkbox"/>	<input type="checkbox"/>	<input type="checkbox"/>
12 Double helical axial stability (2.5.2.3)	<input checked="" type="checkbox"/>	<input type="checkbox"/>	<input type="checkbox"/>	<input checked="" type="checkbox"/>
13 Special testing Integral forged gears (2.5.3.3)				
14 (testing per mutual agreement)	<input type="checkbox"/>	<input type="checkbox"/>	<input type="checkbox"/>	<input type="checkbox"/>
15 Residual unbalance check (2.6.6.2)	<input checked="" type="checkbox"/>	<input type="checkbox"/>	<input type="checkbox"/>	<input checked="" type="checkbox"/>
16 Mechanical Run Test (Main) (4.3.2)	<input checked="" type="checkbox"/>	<input type="checkbox"/>	<input type="checkbox"/>	<input checked="" type="checkbox"/>
17 Mechanical Run Test (Spare) (4.3.2.4)	<input type="checkbox"/>	<input type="checkbox"/>	<input type="checkbox"/>	<input type="checkbox"/>
18 Addl. Mechanical Tests (4.3.2.2.16)	<input type="checkbox"/>	<input type="checkbox"/>	<input type="checkbox"/>	<input type="checkbox"/>
20 Part or Full Load And Full Speed				
21 Test (4.3.3.1)	<input type="checkbox"/>	<input type="checkbox"/>	<input type="checkbox"/>	<input type="checkbox"/>
22 Full torque, reduced speed (4.3.3.2)	<input type="checkbox"/>	<input type="checkbox"/>	<input type="checkbox"/>	<input type="checkbox"/>
23 Full Torque Static Test (4.3.3.3)	<input type="checkbox"/>	<input type="checkbox"/>	<input type="checkbox"/>	<input type="checkbox"/>
24 Back-To-Back Locked Torque				
25 Test (4.3.3.4)	<input type="checkbox"/>	<input type="checkbox"/>	<input type="checkbox"/>	<input type="checkbox"/>
26 Sound Level Test (4.3.3.5)	<input checked="" type="checkbox"/>	<input type="checkbox"/>	<input type="checkbox"/>	<input checked="" type="checkbox"/>
27 Additional gear tooth test (4.2.2.8)	<input type="checkbox"/>	<input type="checkbox"/>	<input type="checkbox"/>	<input type="checkbox"/>
28 Use shop Lube System	<input checked="" type="checkbox"/>	<input type="checkbox"/>	<input type="checkbox"/>	
29 Use job lube system	<input type="checkbox"/>	<input type="checkbox"/>	<input type="checkbox"/>	
30 Use shop Vibration Probes, Etc.	<input type="checkbox"/>	<input type="checkbox"/>	<input type="checkbox"/>	
31 Use job Vibration Probes, Etc.	<input checked="" type="checkbox"/>	<input type="checkbox"/>	<input type="checkbox"/>	
32 Final Assembly, Maintenance &				
33 Running Clearance (4.2.1.1.e)	<input checked="" type="checkbox"/>	<input type="checkbox"/>	<input type="checkbox"/>	<input checked="" type="checkbox"/>
34 Oil System Cleanliness (4.2.3.2)	<input type="checkbox"/>	<input type="checkbox"/>	<input type="checkbox"/>	
35 Oil System-Casing Joint				
36 Tightness (4.3.2.1.4)	<input type="checkbox"/>	<input type="checkbox"/>	<input type="checkbox"/>	
37 Warning And Protection				
38 Devices (4.3.2.1.5)	<input type="checkbox"/>	<input type="checkbox"/>	<input type="checkbox"/>	
39 Seismic Vibration Data (4.3.2.2.3)	<input type="checkbox"/>	<input type="checkbox"/>	<input type="checkbox"/>	<input type="checkbox"/>
40 Vibration, Phase Plots (4.3.2.2.12)	<input checked="" type="checkbox"/>	<input type="checkbox"/>	<input type="checkbox"/>	<input checked="" type="checkbox"/>
41 Oil Inlet Range test (4.3.2.2.13)	<input type="checkbox"/>	<input type="checkbox"/>	<input type="checkbox"/>	<input type="checkbox"/>
42 Tape recorded Vibration Data	<input checked="" type="checkbox"/>	<input type="checkbox"/>	<input type="checkbox"/>	<input checked="" type="checkbox"/>
43 (4.3.2.2.14) (4.3.2.2.15)	<input type="checkbox"/>	Purchaser copy		
44 NON-DESTRUCTIVE TESTING (4.2.1.2) (4.2.2.1)				
45	Surface	Sub surface		Log
46 <input type="checkbox"/> Casing	<input type="checkbox"/>	<input type="checkbox"/>		<input type="checkbox"/>
47 <input checked="" type="checkbox"/> Rot. Elemen.	<input checked="" type="checkbox"/>	<input checked="" type="checkbox"/>		<input checked="" type="checkbox"/>
48 <input checked="" type="checkbox"/> Bearings	<input checked="" type="checkbox"/>	<input checked="" type="checkbox"/>		<input checked="" type="checkbox"/>
49 <input type="checkbox"/> Other :	<input type="checkbox"/>	<input type="checkbox"/>		<input type="checkbox"/>
50 (Specify)				

NOTES :

During start-up, gears can exhibit a transient spike reading of vibration levels that will exceed shutdown settings. Therefore a trip multiplier is recommended in the control system.

Mechanical running test duration 4 hours including

- Shaft vibration record using job vibration probes if ordered
- Bearings temperature records
- Casing vibration measurement
- Sound level pressure measurement
- Power losses measurement at oil outlet
- Performed with oil ISO VG 32

Oil flow requirement and power losses are calculated values only, add normal safety margins for sizing heat exchangers.

**PRELIMINARY MASS ELASTIC DATA**

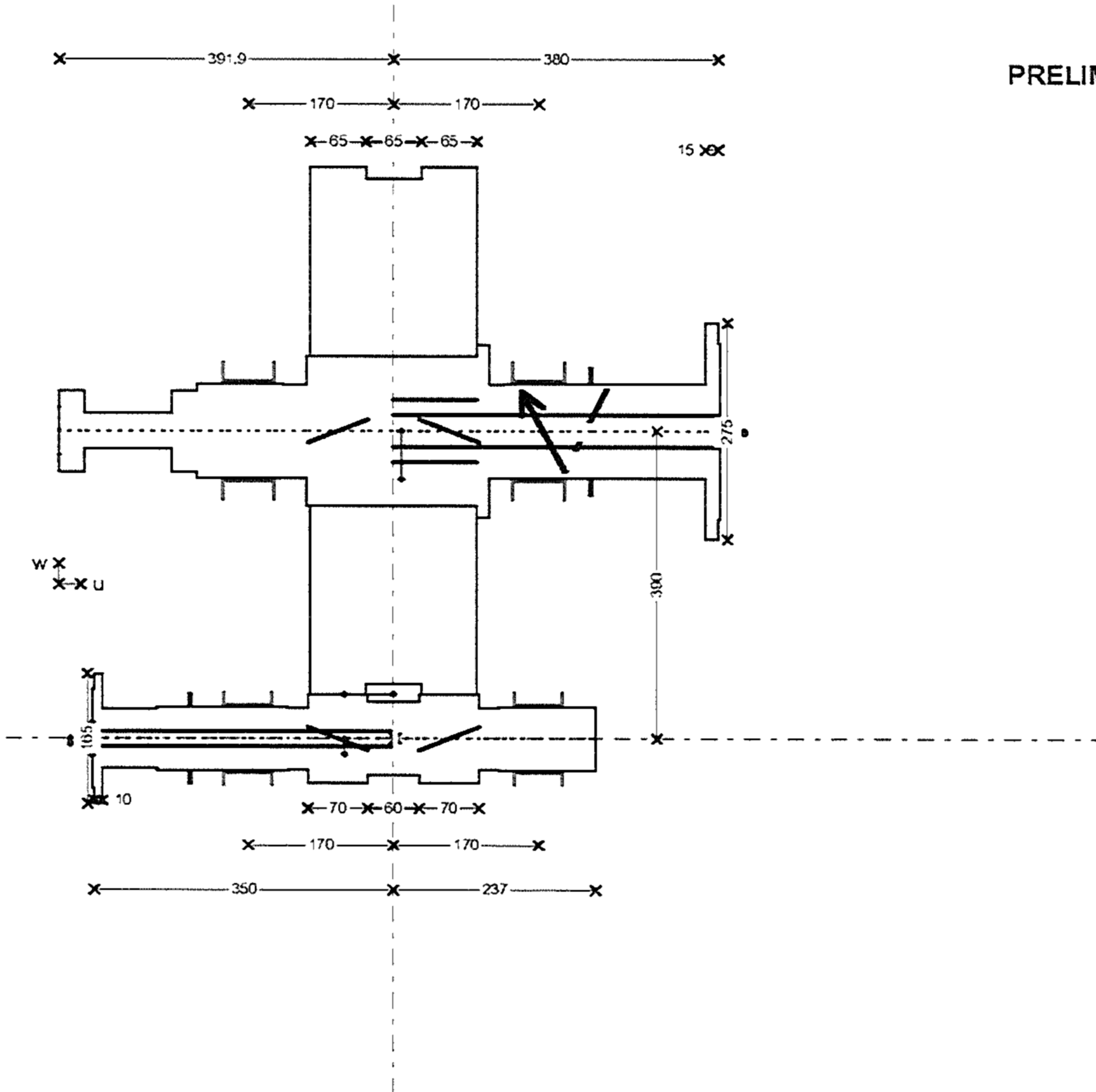

Customer : Siemens AG Duisburg  
 Destination : Khursaniyah Al Fadhli  
 Purchaser order :  
 F-G job number : D 41104B1 OL:  
 Type and serial N° : TX40/5C

Power rating : 1620 kW  
 Service factor :  $AP1613/03 \approx 1,4$   
 Input speed : 1800 rpm  
 Output speed : 10737,9 rpm  
 Speed ratio : 5,96

Weight HSS : 30,5 kg  
 Weight pos. from teeth middle HSS : -57,5 mm  
 Inertia HSS : 0,038 Kg.m<sup>2</sup>  
 Stiffness HSS : 1,11 MNm/rd  
 Bearing type 1 : Tilting pads 80 x 56  
 Bearing type 2 : Tilting pads 80 x 56  
 Add. weight on brg. side 1 : 10,4 kg

Weight LSS : 574,3 kg  
 Weight pos. from teeth middle LSS : 9 mm  
 Inertia LSS : 28,526 Kg.m<sup>2</sup>  
 Stiffness LSS : 6,5 MNm/rd  
 Bearing type 4 : Cylindrical 120 x 60  
 Bearing type 3 : Cylindrical 120 x 60  
 Add. weight on brg. side 4 : 26,4 kg

→  
 Positive direction of external  
 APPAREIL.xls \_ Edition du :06.03.2015



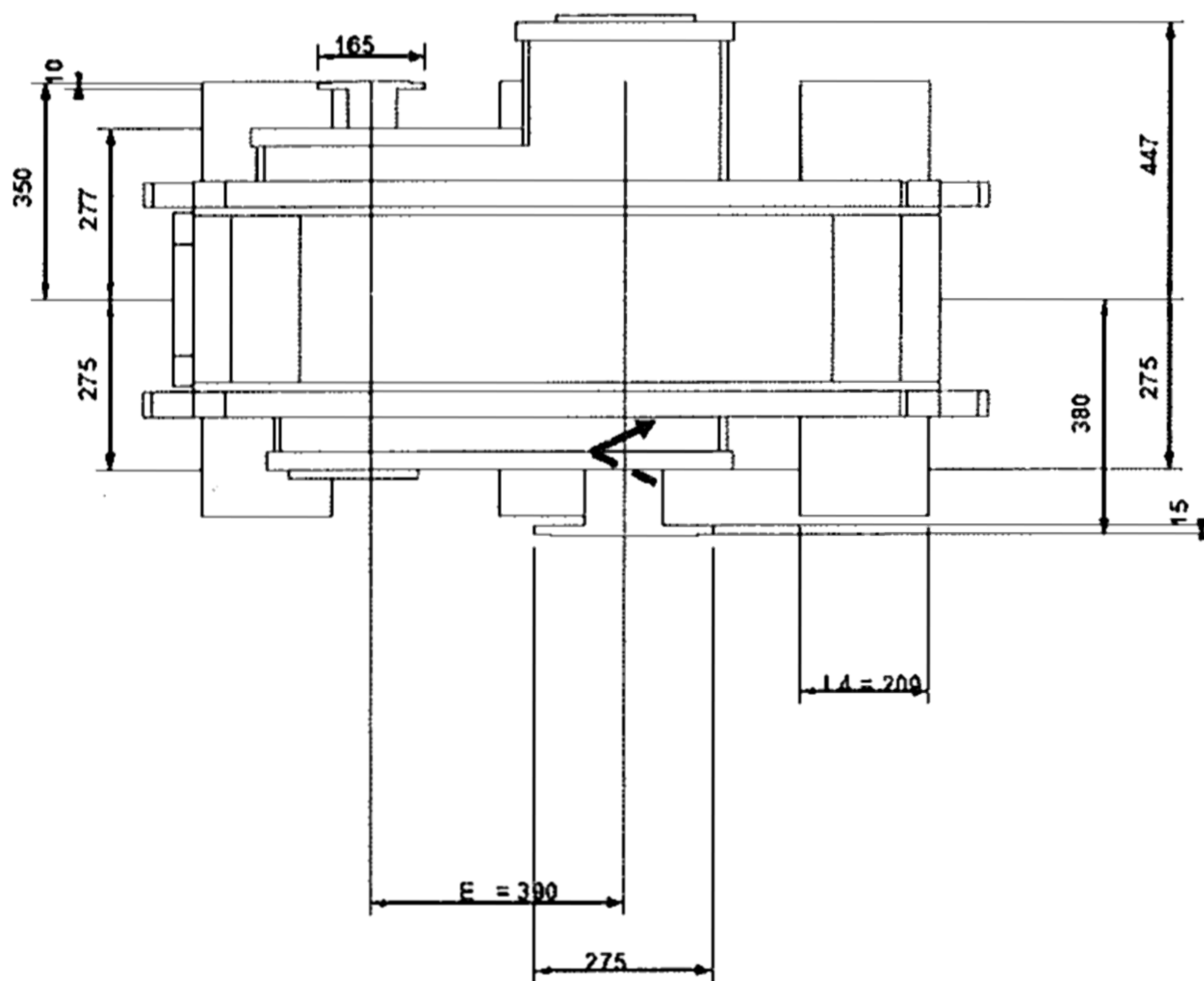
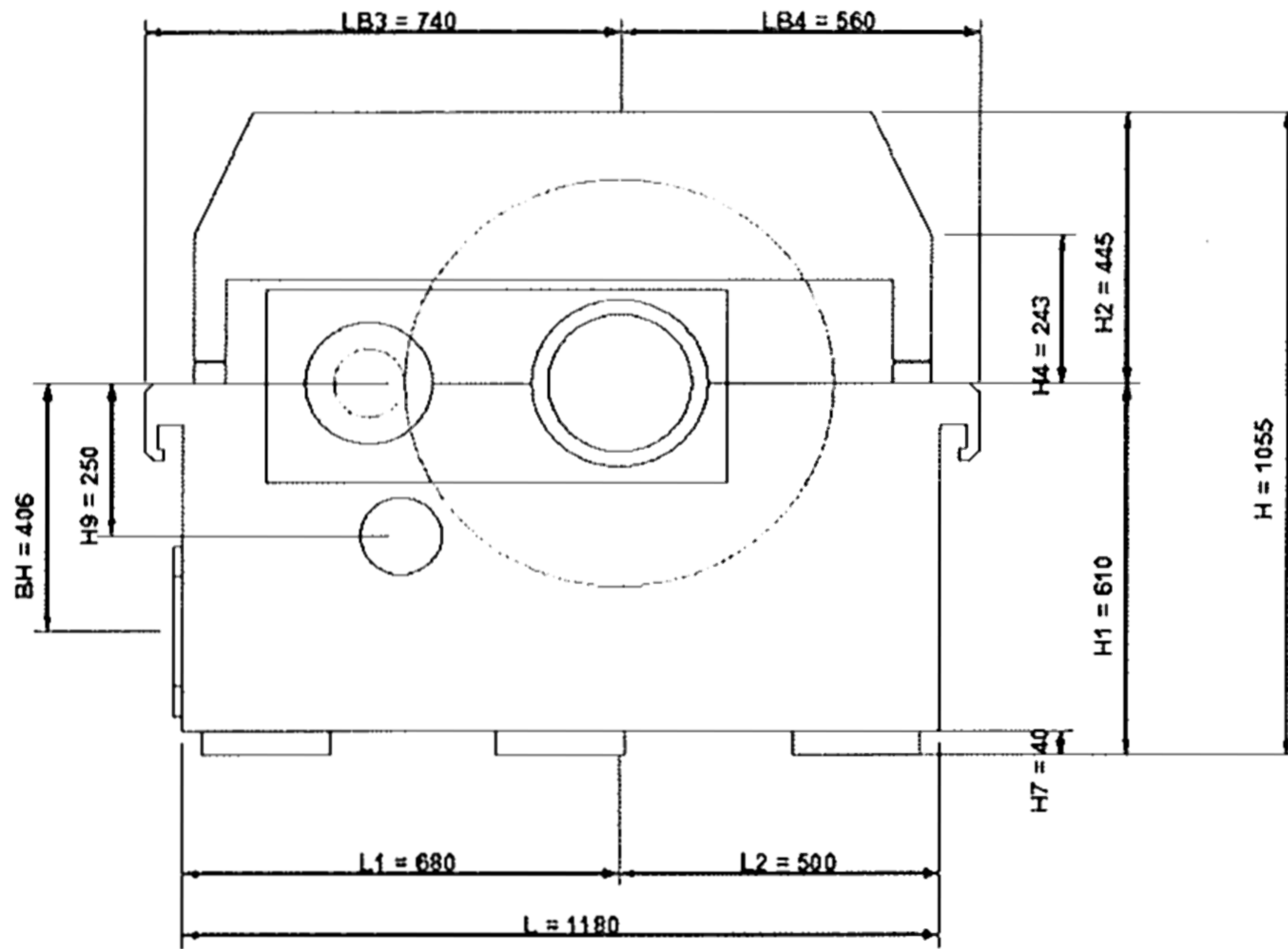

<b>ADDITIONAL TECHNICAL DATASHEET</b>		Job No. <u>41104</u> Item No. <u>B</u>																																																						
		P.O. No. _____ Date _____																																																						
		Requisition No. _____																																																						
		Inquiry No. _____																																																						
		Revision <u>1</u> Date <u>06.03.2015</u> By <u>HNI</u>																																																						
<input checked="" type="checkbox"/> <b>ADDITIONAL GEAR DATA</b>		<input type="checkbox"/> <b>TURNING GEAR (Dimensioning is preliminary !)</b>																																																						
<i>Efficiency</i>		<i>Calculation results</i>																																																						
<table border="1" style="width:100%; border-collapse: collapse;"> <tr> <th>Percent of rated power</th> <th>Efficiency</th> </tr> <tr> <td>100%</td> <td style="text-align: center;"><b>98,70</b></td> </tr> <tr> <td>75%</td> <td style="text-align: center;"><b>98,66</b></td> </tr> <tr> <td>50%</td> <td style="text-align: center;"><b>98,38</b></td> </tr> <tr> <td>25%</td> <td style="text-align: center;"><b>97,42</b></td> </tr> <tr> <td>10%</td> <td style="text-align: center;"><b>87,68</b></td> </tr> </table>		Percent of rated power	Efficiency	100%	<b>98,70</b>	75%	<b>98,66</b>	50%	<b>98,38</b>	25%	<b>97,42</b>	10%	<b>87,68</b>	Required turning speed _____ rpm Actual turning speed _____ rpm Required breakaway torque _____ Nm Actual breakaway torque _____ Nm Actual maximum torque _____ Nm Actual acceleration time _____ s																																										
Percent of rated power	Efficiency																																																							
100%	<b>98,70</b>																																																							
75%	<b>98,66</b>																																																							
50%	<b>98,38</b>																																																							
25%	<b>97,42</b>																																																							
10%	<b>87,68</b>																																																							
<i>Losses</i>		<i>Motor</i>																																																						
Power loss at no load _____ kW Heat rejection _____ kcal/h		Supplier _____ Power _____ kW Voltage _____ V Frequency _____ Hz Speed _____ rpm Electric standard _____																																																						
<input type="checkbox"/> <b>PUMP DETAILS (Dimensioning is preliminary !)</b>		<i>Turning gear</i>																																																						
Design : _____ Speed : _____ rpm Oil flow : _____ l/min Oil pressure : _____ bar NPSH : _____ m Safety valve : _____ Driving method : _____ Material : _____ Flanges : _____ Testing : _____ Furniture of ATEX certificate : _____		Type _____ Ratio _____																																																						
		<i>Clutch</i>																																																						
		Type _____ Max allowable torque _____ Nm																																																						
		<i>Miscellaneous</i>																																																						
		Starting device _____ Switch details _____																																																						
<input checked="" type="checkbox"/> <b>INSTRUMENTATION PACKAGE</b>																																																								
<i>Thermometer</i>		<i>Thermoelements</i>																																																						
<table border="1" style="width:100%; border-collapse: collapse;"> <tr> <th></th> <th>Bearing</th> <th>Thrust bearing</th> <th>Oil inlet/outlet</th> </tr> <tr> <td>Qty</td> <td></td> <td></td> <td></td> </tr> <tr> <td>Type</td> <td></td> <td></td> <td></td> </tr> </table>			Bearing	Thrust bearing	Oil inlet/outlet	Qty				Type				<table border="1" style="width:100%; border-collapse: collapse;"> <tr> <th></th> <th>Bearing</th> <th>Thrust bearing</th> <th>Oil inlet/outlet</th> </tr> <tr> <td>Type</td> <td>DUPLEX 2x3F</td> <td>DUPLEX 2x3F</td> <td></td> </tr> <tr> <td>Classification</td> <td>IEC60751</td> <td>IEC60751</td> <td></td> </tr> <tr> <td>Removable from the outside</td> <td>NO</td> <td>NO</td> <td></td> </tr> <tr> <td>ATEX</td> <td>ATEX Eexia</td> <td>ATEX Eexia</td> <td></td> </tr> </table>			Bearing	Thrust bearing	Oil inlet/outlet	Type	DUPLEX 2x3F	DUPLEX 2x3F		Classification	IEC60751	IEC60751		Removable from the outside	NO	NO		ATEX	ATEX Eexia	ATEX Eexia																						
	Bearing	Thrust bearing	Oil inlet/outlet																																																					
Qty																																																								
Type																																																								
	Bearing	Thrust bearing	Oil inlet/outlet																																																					
Type	DUPLEX 2x3F	DUPLEX 2x3F																																																						
Classification	IEC60751	IEC60751																																																						
Removable from the outside	NO	NO																																																						
ATEX	ATEX Eexia	ATEX Eexia																																																						
<i>Shaft vibrations</i>																																																								
<table border="1" style="width:100%; border-collapse: collapse;"> <tr> <th rowspan="2">Type</th> <th colspan="2">Radial</th> <th colspan="2">Axial</th> <th rowspan="2">Keyphasor</th> <th rowspan="2">Accelerometer</th> </tr> <tr> <th>HS</th> <th>LS</th> <th>HS</th> <th>LS</th> </tr> <tr> <td></td> <td colspan="2">B.N. 3300 XL 8mm Sys. 9M</td> <td colspan="2">BENTLY NEVADA 3300 XL 8mm Sys. 9M</td> <td>B.N. 3300 XL 8mm Sys. 9M</td> <td>ACCELEROMETER BENTLY</td> </tr> <tr> <td>Probe</td> <td>Yes</td> <td></td> <td>No</td> <td></td> <td>Yes</td> <td></td> </tr> <tr> <td>Proximitior</td> <td>Yes</td> <td></td> <td>No</td> <td></td> <td>Yes</td> <td style="background-color: #cccccc;"></td> </tr> <tr> <td>Probe holder</td> <td>Yes</td> <td></td> <td>No</td> <td></td> <td>Yes</td> <td style="background-color: #cccccc;"></td> </tr> <tr> <td>Connection head</td> <td>Yes</td> <td></td> <td>No</td> <td></td> <td>Yes</td> <td style="background-color: #cccccc;"></td> </tr> <tr> <td>mounting kit</td> <td colspan="2" style="background-color: #cccccc;"></td> <td colspan="2" style="background-color: #cccccc;"></td> <td style="background-color: #cccccc;"></td> <td>Yes</td> </tr> </table>				Type	Radial		Axial		Keyphasor	Accelerometer	HS	LS	HS	LS		B.N. 3300 XL 8mm Sys. 9M		BENTLY NEVADA 3300 XL 8mm Sys. 9M		B.N. 3300 XL 8mm Sys. 9M	ACCELEROMETER BENTLY	Probe	Yes		No		Yes		Proximitior	Yes		No		Yes		Probe holder	Yes		No		Yes		Connection head	Yes		No		Yes		mounting kit						Yes
Type	Radial		Axial		Keyphasor	Accelerometer																																																		
	HS	LS	HS	LS																																																				
	B.N. 3300 XL 8mm Sys. 9M		BENTLY NEVADA 3300 XL 8mm Sys. 9M		B.N. 3300 XL 8mm Sys. 9M	ACCELEROMETER BENTLY																																																		
Probe	Yes		No		Yes																																																			
Proximitior	Yes		No		Yes																																																			
Probe holder	Yes		No		Yes																																																			
Connection head	Yes		No		Yes																																																			
mounting kit						Yes																																																		
<i>Junction box(es)</i>		<i>Miscellaneous</i>																																																						
Qty _____ Manufacturer _____ Material _____ ATEX _____		Identification <input checked="" type="checkbox"/> wire <input checked="" type="checkbox"/> conduit <input type="checkbox"/> junction box Conduit type _____ Transmitter type _____ Qty _____ Terminal block type _____ Qty _____																																																						

# FLENDER GRAFFENSTADEN

FLENDER-GRAFFENSTADEN S.A., FRANCE  
BP 84, F-67402 ILLKIRCH-CEDEX  
1, rue du Vieux Moulin  
F-67400 ILLKIRCH-GRAFFENSTADEN

## Commercial Conditions

- Prices are quoted FCA Illkirch-Graffenstaden following Incoterms 2010 including packing cat 1A of SEI, 1999 issue, ind. 2.
- Progress payments : 100% at delivery.
- This quotation is subjected to the Flender Graffenstaden Standard Terms and Conditions of Sales and valid for acceptance until the 15<sup>th</sup> of July 2015.
- Where approval of drawings is required, approval must be in line with the document schedule.
- Warranty period is 18 months of operation or 24 months after delivery whichever occurs first. We recommend the supervision of our engineer for the commissioning.
- Flender-Graffenstaden SAS shall not be obligated to fulfill this agreement if such fulfillment is prevented by any impediments arising out of national or international foreign trade or customs requirements or any embargoes or other sanctions.

## Applicable documents for the quotation (available on demands)

Documents schedule,  
Quality plan  
Painting standard,  
Standard Terms and Conditions of Sales

We thank you for the opportunity of quoting and look forward to the pleasure of serving you.

Very truly yours,

  
N. HOST  
(Project Engineer)

  
Y. FRIEDMANN  
(Sales Manager)

Generated with CAMEC V 4.9.5 26 Feb 2014

**\*\* "This quotation is subject to confidentiality. Information thereof may not be shared with or forwarded to any third parties!"**