

Quotation

To

Company :	Siemens AG	Name :	N. HOST
City / Country :	Duisburg / Germany	Dept :	Sales Dept.
Name :	Stoverink Simon	Tel :	+33 (0)3 69 20 51 50
Dept :		Fax :	+33 (0)3 88 67 60 75
Tel :		E-mail :	nhost@flender-graff.com
Fax :		Page(s) :	19
E-mail :		Copy :	
		Date :	16.03.2015

Y/ref : Khursaniyah Al Fadhili - D43-K-1801 -
O/ref : D41104 quotation number 3

In response to your inquiry referenced above, we are pleased to confirm our quotation as follows :

ITEM A 1 : Flender Graffenstaden (FG) High Speed increaser, model **TX50/4C**

- *Rating conditions :* Rated power at **6800 kW**
Driven by a electric motor at **1800.0 rpm** (specified : 1800.0 rpm)
Driving a centrifugal compressor at **7309.1 rpm** (specified : 7285.0 rpm)
Service factor **1.45** according to **API613/03** (required : > 1.4)
- *Technical description :* Double helical
Manufacturing according to API standard
Flange on LS shaft end
Flange on HS shaft end
Estimated Weight : 4000 kg
- *Bearings description :* 2 cylindrical bearings on LS shaft
2 offset bearings on HS shaft
1 double acting tilting pad thrust bearing on low speed shaft non driven end
- *Mechanical running test :* Full speed, no load test during 4 hours according to the API 613 5th Edition standard.
- *Lubrication conditions :* 164 l/min of Oil ISO VG 46 at 60°C and 2.5 bar at inlet (calculated values only)
- *Miscellaneous:* Efficiency at full load : 99.03 %
Power losses at full load : 66 kW (calculated value only)
Anticipated Sound Pressure Level: 82.0 ± 2dB(A) at 1 meter

Base price : 117 900 EUR each gear box
Delivery time : 36 weeks after the FG acknowledgement of the order
Quantity : 8 gearboxes

Comments :

- Coupling data taken into account on HS Shaft:
 - o Weight: 26.6 kg
 - o Center of gravity position from shaft end: 30.9 mm
 - o Inertia: 0.266 kgm²
- Coupling data taken into account on LS Shaft:
 - o Weight: 87.5 kg
 - o Center of gravity position from shaft end: 40.9 mm
 - o Inertia: 0.875 kgm²

Including :

- Customer witness of test
- After test disassembly and inspection
- Noise level test report
- Lateral analysis undamped
- Documentation : downloadable electronic file in english

Instrumentation (see the complete package on additional technical data sheet):

- *Temperature package*
12 RTD's PT100 Duplex 3 wires from Thermo Electric Company Inc.
(2 per bearing and thrust bearing side) not wired with terminal heads..... Price included
- *Bently Nevada vibration package*
8 radial (4 per shaft) & 2 axial (on LS shaft) vibration probes, 2 accelerometers (1 per shaft), 2
keyphasors (1 per shaft) not wired Price included

Spare parts (Prices are net valid only if spares are ordered together with the gearbox):

- *Commissioning Spares*
2 RTD's, 2 BN vibration probes, 2 BN accelerometers 7 900 EUR Lot Net
- *2 Years Normal Operation Spares*
2 set of bearings with RTD's, 1 set of oil seals 48 420 EUR Lot Net
- *Strategic Spare Parts*
One complete set of rotating elements consisting of one pinion and one gear.
Tested if ordered together with the main gearbox according to API613/03
Full Speed, No Load, with Test Report..... 51 500 EUR Lot Net
- *Container for horizontal spare rotors storage painted according FG standard..... 17 100 EUR Lot Net*

SPECIAL PURPOSE GEAR UNITS
API 613 FIFTH EDITION
DATA SHEET SI UNITS

Job No. 41104 Item No. A
 P.O. No. _____ Date _____
 Requisition No. _____
 Inquiry No. _____
 Revision 1 Date 06.03.2015 By HNI

<p>1 Applicable To: <input checked="" type="radio"/> Proposal <input type="radio"/> Purchase <input type="radio"/> As Built</p> <p>2 For <u>Siemens AG Dulsburg</u></p> <p>3 Site <u>Khursanlyah Al Fadhill</u></p> <p>4 Unit <u>STC-SV 08-4-A</u></p> <p>5 Service <u>EM/CC</u></p> <p>6 No. required <u>9</u></p>	<p><input type="radio"/> US Standards (1.7) <input checked="" type="radio"/> ISO Standards (1.7)</p> <p>Manufacturer <u>FLENDER-GRAFFENSTADEN</u></p> <p>Model No. <u>TX50/4C</u></p> <p>Serial No. _____</p> <p>Driver type <u>electric motor</u></p> <p>Driven equipment <u>centrifugal compressor</u></p>
<p>NOTE : Numbers within () refer to applicable API standard 613 paragraphs</p>	
<p><input type="checkbox"/> Information to be completed by purchaser <input type="checkbox"/> Information to be completed by manufacturer</p>	
<p><input type="checkbox"/> UNITS OF MEASUREMENT</p> <p><input type="checkbox"/> US Customary units</p> <p><input checked="" type="checkbox"/> SI units</p>	<p><input checked="" type="checkbox"/> BASIC GEAR DATA</p>
<p><input type="checkbox"/> RATING REQUIREMENTS</p>	<p><input checked="" type="radio"/> Single stage <input type="radio"/> Single helical</p> <p><input type="radio"/> Double stage <input checked="" type="radio"/> Double helical</p> <p><input type="radio"/> Epicyclic <input type="radio"/> horizontal offset</p>
<p>14 Driven equip. (2.1.4): Norm. _____ Max _____ kW</p> <p>15 Driver: Rated _____ Max _____ kW</p> <p>16 Normal transmitted power (2.2.2) _____ kW</p> <p>17 Gear unit rated power (2.2.1) <u>6800</u> kW</p> <p>18 Torque @ max cont speed _____ Nm</p> <p>19 Max torque (2.2.1) _____ Nm @ _____ rpm</p> <p>20 <input type="radio"/> Reducer <input checked="" type="radio"/> Increaser</p> <p>21 Rated speed (2.1.5):</p> <p>22 Input <u>1800</u> rpm <input type="radio"/> Specified <input checked="" type="radio"/> Nominal</p> <p>23 Output <u>7285</u> rpm <input type="radio"/> Specified <input checked="" type="radio"/> Nominal</p> <p>24 Allow var in gear ratio (2.1.6) (+) (-) _____ %</p> <p>25 Max continuous speed (1.5) <u>1800 / 7285</u> rpm</p> <p>26 Trip speed (1.5) (2.1.7) <u>1980 / 8013,5</u> rpm</p> <p>27 Gear service factor (2.2.3.1) <u>1,4 API 613/2003 5 TH</u> (min)</p> <p>28 Hardness (2.2.3.2) Pinion _____ Gear _____</p> <p>29 Shaft assembly designation (2.1.19) _____ L/R</p> <p>30 HS shaft rot fac'g cpl'g (2.1.20.2) <input checked="" type="checkbox"/> CW <input type="checkbox"/> CCW</p> <p>31 LS shaft rot fac'g cpl'g (2.1.20.2) <input checked="" type="checkbox"/> CW <input type="checkbox"/> CCW</p> <p>32 External loads (2.1.16) _____</p> <p>33 Other operating conditions (2.2.2) (2.6.1.3) _____</p>	<p>Mechanical rating (1.5.16) <u>9520</u> kW @ <u>1800 / 7309,1</u> rpm</p> <p>Gear service factor (2.2.3.1) <u>1,44 API 613/2003 5 TH</u> (actual)</p> <p>Full load gear unit power loss _____ kW</p> <p>Gear Unit Mechanical efficiency <u>99,03</u> %</p> <p>Rating speed Pinion <u>7,309,1</u> Gear <u>1,800,0</u> rpm</p> <p>Hardness used for</p> <p>Rating, (HB or Rc) Pinion <u>58 HRC</u> Gear <u>58 HRC</u></p> <p>Tooth pitting index, "K" (2.2.4.1) (2.2.4.2)</p> <p>Allowable <u>2,17</u> Actual <u>2,10</u> MPa</p> <p>Material index number (Fig 3, Table 4) <u>3,03</u> MPa</p> <p>Bending stress number, "S_b" (2.2.5.1) (2.2.5.2)</p> <p>Pinion: Allowable <u>265,4</u> Actual <u>256,0</u> MPa</p> <p>Gear: Allowable <u>265,4</u> Actual <u>240,9</u> MPa</p> <p>Pitch line velocity <u>77,1</u> m/s</p> <p>Anticipated SPL (2.1.6) <u>82</u> dB(A) @ <u>1</u> m</p> <p>WR² referred to LS shaft <u>126,12</u> kgm²</p> <p>Breakaway torque <u>412</u> Nm @ LS Shaft</p> <p>Pinion teeth hardness range <u>58 - 63 HRC</u></p> <p>Pinion teeth hardening method <u>CARBURIZED</u></p> <p><input type="checkbox"/> HS shaft separate hardness range _____</p> <p>Gear teeth (rim) hardness range <u>58 - 63 HRC</u></p> <p>Gear teeth hardening method <u>CARBURIZED</u></p> <p>Gear hub:</p> <p><input checked="" type="checkbox"/> Forged cylinder <input type="checkbox"/> Forged & Copped <input type="checkbox"/> Fabricated</p> <p>Gear to Shaft fit method (2.5.3.2)</p> <p><input type="checkbox"/> Integral <input type="checkbox"/> Keyed interference <input checked="" type="checkbox"/> Keyless interference</p> <p>Rim attachment (2.5.3.2) <u>FORGED GEAR WHEEL</u></p> <p>LS shaft hardness range <u>HB 230 - 274</u></p> <p>Journal static weight loads (2.6.6.3)</p> <p>Pinion <u>128 / 42</u> kg Gear <u>942 / 707</u> kg</p> <p>Total gear unit assembled weight <u>4000</u> kg</p> <p>NOTES : _____</p>
<p><input type="checkbox"/> INSTALLATION DATA (2.1.14)</p>	
<p>36 <input type="checkbox"/> Indoor <input type="checkbox"/> Heated <input type="checkbox"/> Under roof</p> <p>37 <input checked="" type="checkbox"/> Outdoor <input type="checkbox"/> Unheated <input type="checkbox"/> Partial slides</p> <p>38 <input type="checkbox"/> Grade <input type="checkbox"/> Mazzanine <input checked="" type="checkbox"/> ONSHORE</p> <p>39 <input type="checkbox"/> Winterization required <input type="checkbox"/> Tropicalization required</p> <p>40 Electrical area (2.1.10) Class _____ Grp _____ Div _____</p> <p>41 Electrical area (2.1.10) Zone <u>2</u> Grp <u>IIA</u> Temp <u>T1</u> °C</p> <p>42 Max allow SPL (2.1.6) _____ dB(A) @ _____ m</p> <p>43 Elevation _____ m Barometer _____ kPa abs</p> <p>44 Range of ambient temperatures:</p> <p>45 Dry bulb _____ Wet bulb _____</p> <p>46 Normal _____ °C _____ °C</p> <p>47 Maximum <u>82</u> °C _____ °C</p> <p>48 Minimum <u>0</u> °C _____ °C</p> <p>49 Unusual conditions <input type="checkbox"/> Dust <input type="checkbox"/> Fumes</p> <p>60 <input type="checkbox"/> _____</p>	

SPECIAL PURPOSE GEAR UNITS
API 613 FIFTH EDITION
DATA SHEET SI UNITS

Job No. 41104 Item No. A
P.O. No. _____ Date _____
Requisition No. _____
Inquiry No. _____
Revision 1 Date 06.03.2015 By HNI

■ GEAR DATA				○ COUPLINGS AND GUARDS		
	Pinion	Gear		Pinion	Gear	
3	Number of teeth	<u>33</u>	<u>134</u>	Coupling furnished by (3.2.1)	<u>Compr. Supplier</u>	<u>Compr. Supplier</u>
4	Gear ratio	<u>4,06</u>		Mount coupling halves (3.2.2)	<u>Compr. Supplier</u>	<u>Compr. Supplier</u>
5	Tangential load, "Wt" (2,2,4,2)	<u>88.155</u>		Cplg. guard adapter by (3.2.3)	<u>Gear Supplier</u>	<u>Gear Supplier</u>
6	AGMA Geometry factor "J"	<u>0,55</u>	<u>0,57</u>	Cplg. guard furnished by (3.2.3)	<u>Compr. Supplier</u>	<u>Compr. Supplier</u>
7	Pitch diameter	<u>201,56</u>	<u>818,44</u>	Coupling vendor (3.2.3)		
8	Outside diameter	<u>214,10</u>	<u>827,60</u>	Vendor's model number (3.2.3)		
9	Root diameter	<u>187,25</u>	<u>800,74</u>	Coupling weight on shaft, kg	<u>26,6</u>	<u>87,5</u>
10	Center groove diameter	<u>177,00</u>	<u>790,00</u>	CG inboard / outboard of shaft end	<u>Outboard</u>	<u>Outboard</u>
11	Normal pressure angle	<u>20,00</u>		Hub drill template provided	<input type="checkbox"/>	<input type="checkbox"/>
12	Normal diametral pitch	<u>4,62</u>		■ SHAFT END DETAIL (2.5.4.2)		
13	Helix angle	<u>25,00</u>		Shaft end detail specified by: <input checked="" type="radio"/> Purchaser <input type="radio"/> Gear vendor		
14	Center distance	<u>510,00</u>		(Integral unless otherwise specified)		
15	Backlash min	<u>0,34</u>		Shaft end detail if 'otherwise' specified:		
16	Net face width, "Fw"	<u>260,00</u>		Pinion	Gear	
17	Pinion L/D	<u>1,71</u>		Tapered / Keyless	<input type="radio"/> <input type="checkbox"/>	<input type="radio"/> <input type="checkbox"/>
18	Face overlap ratio	<u>6,36</u>		Tapered / 1-Key	<input type="radio"/> <input type="checkbox"/>	<input type="radio"/> <input type="checkbox"/>
19	Transverse contact ratio	<u>1,45</u>		Tapered / 2-Keys	<input type="radio"/> <input type="checkbox"/>	<input type="radio"/> <input type="checkbox"/>
20	AGMA 6011 service factor	<u>2,64</u>		Cylindrical / 1-Key	<input type="radio"/> <input type="checkbox"/>	<input type="radio"/> <input type="checkbox"/>
21	Rating based on ANSI/AGMA 6011 with SF=1.0			Cylindrical / 2-Keys	<input type="radio"/> <input type="checkbox"/>	<input type="radio"/> <input type="checkbox"/>
22	Durability Power	<u>21442</u>		Other <u>Flanged</u>	<input checked="" type="radio"/> <input type="checkbox"/>	<input checked="" type="radio"/> <input type="checkbox"/>
23	Strength Power	<u>17946</u>		Shaft diameter	<u>120,0</u>	<u>190,0</u> mm
24	Tooth Surface Finish, Ra	<u>0,4</u>	<u>0,4</u>	(if integral flange use diameter immediately adjacent to flange)		
25	Tooth Generation Process	<u>Hobbling</u>	<u>Hobbling</u>	■ RADIAL BEARINGS		
26	Tooth Finishing Process	<u>Grinding</u>	<u>Grinding</u>	Type	<u>OFFSET / OFFSET</u>	<u>CYL. / CYL.</u>
27	Lead modification (2.2.4.6)	<input checked="" type="radio"/> Not Req'd	<input type="radio"/> Req'd	Diameter	<u>130 / 130</u>	<u>200 / 200</u> mm
28	Calculated Total Lead Mismatch			Length	<u>130 / 130</u>	<u>100 / 100</u> mm
29				Journal velocity	<u>49,8 / 49,8</u>	<u>18,8 / 18,8</u> m/s
30	■ SCUFFING DATA (2.2.6)			Loading	<u>2,78 / 2,81</u>	<u>2,87 / 2,71</u> Nmm ²
31	Scuffing Data per ANSI/AGMA 926-A03			Clearance (min-max)		
32	Scuffing Risk (2.2.6) <=5% (Low)	Calculation Method	<u>AGMA925</u>	Span	<u>550</u>	<u>550</u> mm
33	Composite surface roughness, σ_x	<u>0,57</u>		Power loss each bearing	<u>13,8 / 13,8</u>	<u>3,0 / 3,0</u> kW
34	Specific film thickness, EHL A_{min}	<u>3,31</u>		Oil flow each bearing	<u>42,0 / 42,0</u>	<u>10,0 / 10,0</u> l/min
35	Tooth temperature, θ_m	<u>82</u>		■ THRUST BEARINGS		
36	Maximum contact temperature, θ_{Bmax}	<u>101</u>		Location	<u>OPP.CPLG.SIDE</u>	
37				Manufacturer	<u>FLENDER</u>	
38	■ MATERIALS			Type	<u>NO</u>	
39	Gear casing	<u>Steel</u>	Oil seals <u>aluminium</u>	Size	<u>BPK LEG 6"</u>	
40	Pinion(s)	<u>18CrNiMo7-6</u>		Area	<u>11615</u> mm ²	
41	Gear rim(s)	<u>18CrNiMo7-6</u>		Loading	<u>1,14</u> MPa	
42	HS Shaft	<u>Integral</u>	LS Shaft <u>42CrMo4</u>	Rating	<u>1,50</u> MPa	
43	Radial bearings	<u>Babbitt</u>	Backing <u>Steel</u>	Int. thrust load		
44	Thrust bearing(s)	<u>Babbitt</u>	Backing <u>Steel</u>	Ext. thrust load	<u>4,050</u>	<u>9,200</u> N
45				Power loss each	<u>0,0</u>	<u>6,0</u> kW
46	○ SHAFT END DETAIL			Oil flow each bearing	<u>0,0</u>	<u>20,0</u> l/min
47	<input checked="" type="checkbox"/> Gear shaft end for coupling integral flange (2.5.4.2)			NOTES : _____		
48	<input checked="" type="checkbox"/> Pinion shaft end for coupling integral flange (2.5.4.2)					
49	<input checked="" type="checkbox"/> Other : <u>WITHOUT BOLTS</u>					

SPECIAL PURPOSE GEAR UNITS
API 613 FIFTH EDITION
DATA SHEET SI UNITS

1 **○ LUBRICATION REQUIREMENTS**

2 Oil system furnished by (2.8.3) _____

3 Other _____ Gear vendor _____

4 Oil visc. _____ cp @ 40°C _____ cp @ 100°C (2.8.6)

5 ISO Grade _____ Load stage (2.2.6) **5,0**

6 **■ MESH**

7

8 Mesh and windage power loss **26,4** kW

9 Oil flow, mesh **40,0** l/min

10

11 **■ LUBRICATION REQUIREMENTS**

12 Min. startup oil temperature **20,0** °C

13 Normal oil inlet temperature **60,0** °C

14 Maximum oil inlet temperature **65,0** °C

15 Unit oil flow (total) **164,0** l/min

16 Unit oil pressure **2,5** bar

17 Oil visc. _____ cp @ 40°C _____ cp @ 100°C (2.8.6)

18 ISO Grade **46** Load stage (2.2.6) **5,0**

19

20 **■ PIPING CONNECTIONS**

Service	No.	Size	Type
Lube oil inlet	1	2 in.	ANSI 150 LBS
Lube oil outlet	1	6 in.	ANSI 150 LBS
Casing drain *			
Vent	1	1,5 in.	ANSI 150 LBS
Casing purge			

27 * Casing drain is 'dead bottom' housing drain, not lube oil outlet

28 **○ MOUNTING PLATES**

29 Gear furnished with (3.3.1.1)

30 Baseplate Soleplate Subplate(s) (3.3.2.10)

31 Mounting plates(s) furnished by (3.3.1.1) _____

32 Baseplate leveling (3.3.2.3) _____

33 Baseplate with leveling pads (3.3.2.3)

34 Baseplate suitable for column mounting (3.3.2.4)

35 Vendor review of purchaser's foundation dwgs. (2.1.13)

36 Grout type (3.3.1.2.4) _____

37

38 **○ CONTRACT DATA**

39 Test data prior to shipment _____

40 Progress report (5.3.3) _____

41 Vendor signoff of inspector checklist (4.1.1.3)

42 Information retained for 20 years (4.2.1.1) (4.2.2.6.1)

43 Technical manual (5.3.5.4)

44 PAINTING (4.4.3.1) Flender standard RAL5015 (blue)

45 Painting housing interior not allowed (2.3.1.14)

46 **○ SHIPMENT**

47 Steel rotor storage container (4.4.5) Shaft covers (4.4.4)

	Contract unit	Spares
Export boxing	<input type="checkbox"/>	<input type="checkbox"/>
Domestic boxing	<input type="checkbox"/>	<input type="checkbox"/>
Outdoor storage over 6 mos.	<input type="checkbox"/>	3 years Indoor <input type="checkbox"/> (4.4.3.9)

Job No. **41104** Item No. **A**

P.O. No. _____ Date _____

Requisition No. _____

Inquiry No. _____

Revision **1** Date **06.03.2015** By **HNI**

○ ADDITIONAL REQUIREMENTS

○ VIBRATION DETECTORS

RADIAL (3.4.2.1) (2.7.4.5) (2.7.4.6)

Manufacturer **BENTLY NEVADA** Total No. **8**

X-Y probes pinion bearings Coupling end Blind end

X-Y probes gear bearings Coupling end Blind end

Other _____

AXIAL (3.4.2.1) (2.7.4.5) (2.7.4.6)

Manufacturer **BENTLY NEVADA** Total No. **2**

Dual probes at each thrust bearing

Single probe any shaft without thrust bearing

Other _____

ONE EVENT PER REVOLUTION PROBE (2.7.4.5) (2.7.4.6)

Manufacturer **BENTLY NEVADA** Total No. **2**

One on input shaft One on output shaft

Other _____

ACCELEROMETER (3.4.2.1) (2.7.4.5) (2.7.4.6)

Manufacturer **BENTLY NEVADA** No. required **2**

Pinion coupling end Gear coupling end

Other _____

○ TEMPERATURE DETECTORS

Dial type thermometers (3.4.2.7) _____

Type brg. temp. sensors (3.4.2.7) (2.7.1.3) **PT100**

RTD Thermocouple / Simplex Duplex

Calibration **Yes**

HSALS bearings no. sensors each **2** / **2**

Thrust number of sensing elements each face **2**

○ OTHER VIBRATION AND TEMPERATURE

(3.4.2.5) (3.4.2.6) Other Gear vendor

Oscillator demodulator supplied by

Vibration monitor supplied by

Vibration shutdown delay time _____ seconds

Temperature monitor supplied by

Oscillator demodulator J-box by

Temp. sensor termination J-box by

J-box type _____ Mount _____

○ MISCELLANEOUS

Undamped critical analysis report (2.6.2.1)

w/ dampd rotr respsn analys rpt (2.6.2.4.3) (2.6.2.6)

Torsional analysis by (2.6.5.2) Gear vendor Other

Spare set of gear rotors (4.3.2.4)

Gear case furnished with inlet purge connection (2.4.3)

Orientation of oil inlet & drain conns. (2.4.6) _____

Filter breather location (2.3.1.12) **Prov. on upper casing**

Torsional device provisions (2.5.4.5) _____

Rotor vertical storage provisions (2.5.4.8) _____

Rotor vertical storage fixture(s) (3.6.2) _____

Vendor service rep. on site (2.1.13)

PRELIMINARY MASS ELASTIC DATA

Customer : Siemens AG Duisburg
 Destination : Khursariyah Al Fadhili
 Purchaser order :
 F-G job number : D 41104A1 OL
 Type and serial N° : TX50/4C

Power rating : 6800 kW
 Service factor : AP1613.03 >=1,4
 Input speed : 1800 rpm
 Output speed : 7309,1 rpm
 Speed ratio : 4,06

Weight HSS : 143,5 kg
 Weight pos. from tooth middle HSS : -63,4 mm
 Inertia HSS : 0,585 Kg.m²
 Stiffness HSS : 5,916 MN/mrd
 Bearing type 1 : Offset 130 x 130
 Bearing type 2 : Offset 130 x 130
 Add. weight on brg. side 1 : 26,6 kg

Weight LSS : 1561,2 kg
 Weight pos. from tooth middle LSS : 10,5 mm
 Inertia LSS : 116,473 Kg.m²
 Stiffness LSS : 39,014 MN/mrd
 Bearing type 4 : Cylindrical 200 x 100
 Bearing type 3 : Cylindrical 200 x 100
 Add. weight on brg. side 4 : 87,5 kg

Positive direction of external

APPAREIL_xis_ Edition du :06.03.2015
 1/1

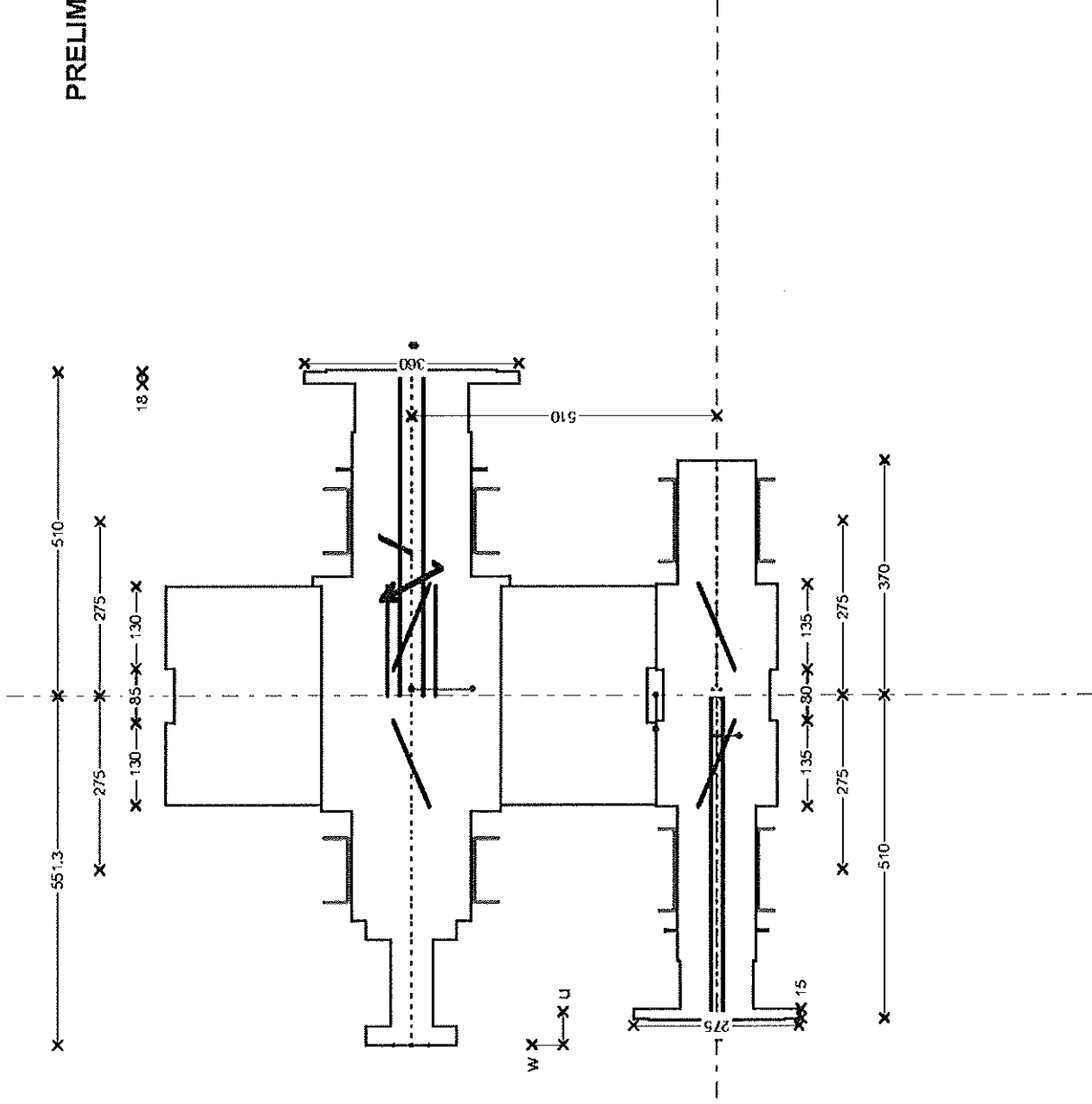

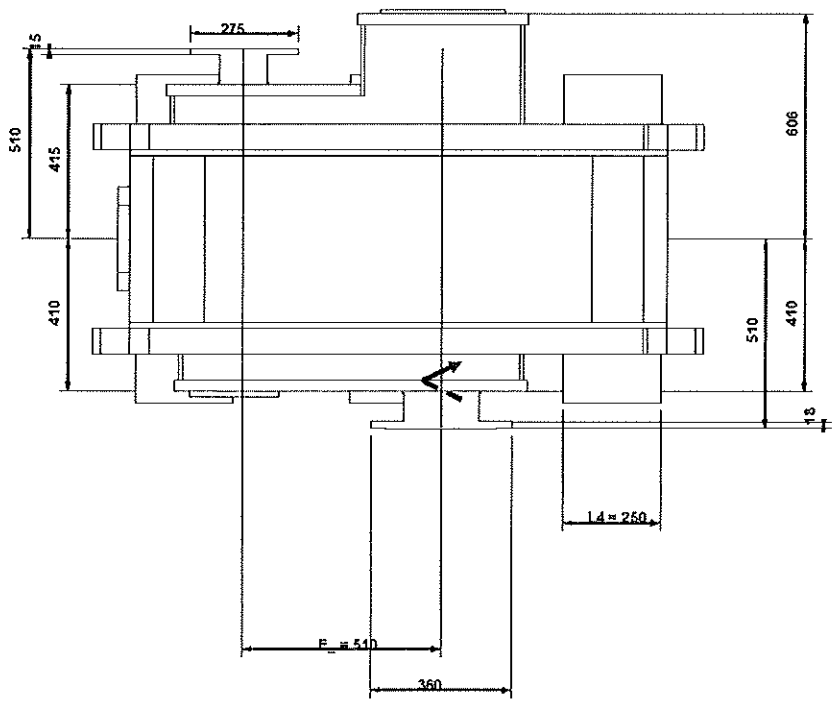
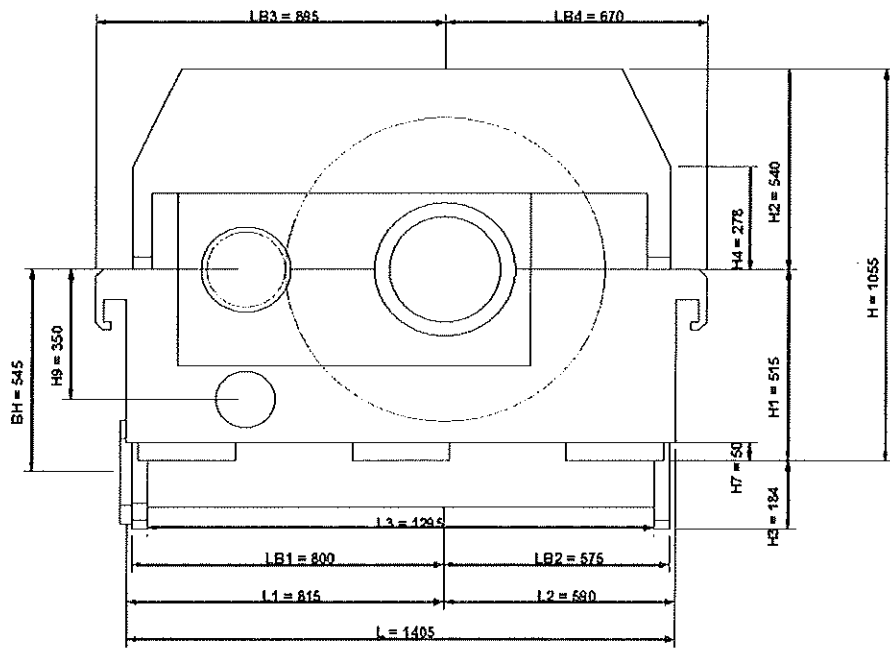

ADDITIONAL TECHNICAL DATASHEET

Job No. 41104 Item No. A
 P.O. No. _____ Date _____
 Requisition No. _____
 Inquiry No. _____
 Revision 1 Date 06.03.2016 By HNI

1	<input checked="" type="checkbox"/> ADDITIONAL GEAR DATA			<input type="checkbox"/> TURNING GEAR (Dimensioning is preliminary !)		
2	<i>Efficiency</i>			<i>Calculation results</i>		
3	Percent of rated power	Efficiency		Required turning speed	_____	rpm
4	100%	99,03		Actual turning speed	_____	rpm
5	75%	98,92		Required breakaway torque	_____	Nm
6	50%	98,79		Actual breakaway torque	_____	Nm
7	25%	98,08		Actual maximum torque	_____	Nm
8	10%	90,80		Actual acceleration time	_____	s
9						
10	<i>Losses</i>			<i>Motor</i>		
11	Power loss at no load	_____	kW	Supplier	_____	
12	Heat rejection	_____	kcal/h	Power	_____	kW
13				Voltage	_____	V
14				Frequency	_____	Hz
15	<input type="checkbox"/> PUMP DETAILS (Dimensioning is preliminary !)			Speed	_____	rpm
16				Electric standard	_____	
17	Design :	_____		<i>Turning gear</i>		
18	Speed :	_____	rpm	Type	_____	
19	Oil flow :	_____	l/min	Ratio	_____	
20	Oil pressure :	_____	bar	<i>Clutch</i>		
21	NPSH :	_____	m	Type	_____	
22	Safety valve :	_____		Max. allowable torque	_____	Nm
23	Driving method :	_____		<i>Miscellaneous</i>		
24	Material :	_____		Starting device	_____	
25	Flanges :	_____		Switch details	_____	
26	Testing :	_____				
27	Furniture of ATEX certificate :	_____				
28						
29						
30	<input checked="" type="checkbox"/> INSTRUMENTATION PACKAGE					
31	<i>Thermometer</i>			<i>Thermoelements</i>		
32						
33		Bearing	Thrust bearing	Oil inlet/outlet		
34	Qty				Bearing	Thrust bearing
35	Type				DUPLEX 2x3F	DUPLEX 2x3F
36					Classification	IEC60751
37					Removable from the outside	NO
38					ATEX	ATEX Eexia
39					ATEX Eexia	ATEX Eexia
40	<i>Shaft vibrations</i>					
41						
42		Radial	Axial	Keyphasor	Accelerometer	
43	Type	B.N. 3300 XL 8mm Sys. 9M	HS LS	B.N. 3300 XL 8mm Sys. 9M	ACCELEROMETER BENTLY	
44			No			
45	Probe	Yes	HS LS	Yes		
46			No			
47	Proximitor	Yes	HS LS	Yes		
48			No			
49	Probe holder	Yes	HS LS	Yes		
50			Yes			
51	Connection head	Yes	HS LS	Yes		
52			No			
53	mounting kit		LS	Yes	Yes	
54						
55	<i>Junction box(es)</i>			<i>Miscellaneous</i>		
56				Identification	<input checked="" type="checkbox"/> wire	<input checked="" type="checkbox"/> conduit
57	Qty	0		Conduit type	_____	<input type="checkbox"/> junction box
58	Manufacturer	_____		Transmitter type	_____	Qty _____
59	Material	_____		Terminal block type	_____	Qty _____
60	ATEX	None				
61						

FLENDER GRAFFENSTADEN

FLENDER-GRAFFENSTADEN S.A., FRANCE
BP 84, F-67402 ILLKIRCH-CEDEX
1, rue du Vieux Moulin
F-67400 ILLKIRCH-GRAFFENSTADEN

Y/ref : Khursaniyah Al Fadhili - D43-K-3801 -
O/ref : D41104 quotation number 3

ITEM B 1 : Flender Graffenstaden (FG) High Speed increaser, model TX40/5C

- *Rating conditions* : Rated power at **1620 kW**
Driven by a electric motor at **1800.0 rpm** (specified : 1800.0 rpm)
Driving a centrifugal compressor at **10737.9 rpm** (specified : 10736.0 rpm)
Service factor **1.47** according to **API613/03** (required : > 1.4)

- *Technical description* : Double helical
Manufacturing according to API standard
Flange on LS shaft end
Flange on HS shaft end
Estimated Weight : 1900 kg

- *Bearings description* : 2 cylindrical bearings on LS shaft
2 tilting pads bearings on HS shaft
1 double acting tilting pad thrust bearing on low speed shaft non driven end

- *Mechanical running test* : Full speed, no load test during 4 hours according to the API 613 5th Edition standard.

- *Lubrication conditions* : 64 l/min of Oil ISO VG 46 at 60°C and 2.5 bar at inlet (calculated values only)

- *Miscellaneous*: Efficiency at full load : 98.70 %
Power losses at full load : 21 kW (calculated value only)
Anticipated Sound Pressure Level: 82.0 ± 2dB(A) at 1 meter

Base price : **103 850 EUR** each gear box

Delivery time : **36 weeks** after the FG acknowledgement of the order

Quantity : **1 gearbox**

Comments :

- Coupling data taken into account on HS Shaft:
 - o Weight: 10.4 kg
 - o Center of gravity position from shaft end: 28.2 mm
 - o Inertia: 0.104 kgm²
- Coupling data taken into account on LS Shaft:
 - o Weight: 26.4 kg
 - o Center of gravity position from shaft end: 30.9 mm
 - o Inertia: 0.264 kgm²

Including :

- Customer witness of test
- After test disassembly and inspection
- Noise level test report
- Lateral analysis undamped
- Documentation : downloadable electronic file in English

Instrumentation (see the complete package on additional technical data sheet):

- *Temperature package*
12 RTD's PT100 Duplex 3 wires from Thermo Electric Company Inc.
(2 per bearing and thrust bearing side) not wired with terminal heads..... Price included
- *Bently Nevada vibration package*
8 radial (4 per shaft) & 2 axial (on LS shaft) vibration probes, 2 accelerometers (1 per shaft), 2 keyphasors (1 per shaft) not wired Price included

Spare parts (Prices are net valid only if spares are ordered together with the gearbox):

- *Commissioning Spares*
2 RTD's, 2 BN vibration probes, 2 BN accelerometers 7 900 EUR Lot Net
- *2 Years Normal Operation Spares*
1 set of bearings with RTD's, 1 set of oil seals 26 010 EUR Lot Net
- *Strategic Spare Parts*
One complete set of rotating elements consisting of one pinion and one gear.
Tested if ordered together with the main gearbox according to API613/03
Full Speed, No Load, with Test Report..... 37 100 EUR Lot Net
- *Container for horizontal spare rotors storage painted according FG standard..... 15 850 EUR Lot Net*

SPECIAL PURPOSE GEAR UNITS
API 613 FIFTH EDITION
DATA SHEET SI UNITS

Job No. 41104 item No. B
 P.O. No. _____ Date _____
 Requisition No. _____
 Inquiry No. _____
 Revision 1 Date 06.03.2015 By HNI

Applicable To: Proposal Purchase As Built
 US Standards (1.7) ISO Standards (1.7)

For Siemens AG Dulsburg Manufacturer FLENDER-GRAFFENSTADEN
 Site Khursaniyah Al Fadhli Model No. TX40/5C
 Unit STC-SV 06-3-A Serial No. _____
 Service EM/CC Driver type electric motor
 No. required 1 Driven equipment centrifugal compressor

NOTE : Numbers within () refer to applicable API standard 613 paragraphs

Information To be completed by purchaser Information to be completed by manufacturer

UNITS OF MEASUREMENT BASIC GEAR DATA

US Customary units
 SI units

RATING REQUIREMENTS

Driven equip. (2.1.4): Norm. _____ Max _____ kW
 Driver: Rated _____ Max _____ kW
 Normal transmitted power (2.2.2) _____ kW
 Gear unit rated power (2.2.1) 1620 kW
 Torque @ max cont speed _____ Nm
 Max torque (2.2.1) _____ Nm @ _____ rpm
 Reducer Increaser
 Rated speed (2.1.5):
 Input 1800 rpm Specified Nominal
 Output 10736 rpm Specified Nominal
 Allow var in gear ratio (2.1.5) (+) (-) _____ %
 Max continuous speed (1.5) 1800 / 10736 rpm
 Trip speed (1.5) (2.1.7) 1980 / 11809,6 rpm
 Gear service factor (2.2.3.1) 1,4 API 613/2003 5 TH (min)
 Hardness (2.2.3.2) Pinion _____ Gear _____
 Shaft assembly designation (2.1.10) L/R
 HS shaft rot fac'g cpl'g (2.1.20.2) CW CCW
 LS shaft rot fac'g cpl'g (2.1.20.2) CW CCW
 External loads (2.1.16) _____
 Other operating conditions (2.2.2) (2.6.1.3) _____

INSTALLATION DATA (2.1.14)

Indoor Heated Under roof
 Outdoor Unheated Partial sides
 Grade Mezzanine **ONSHORE**
 Winterization required Tropicalization required

Electrical area (2.1.10) Class _____ Grp _____ Div _____
 Electrical area (2.1.10) Zone 2 Grp IIA Temp T1 °C
 Max allow SPL (2.1.6) _____ dB(A) @ _____ m
 Elevation _____ m Barometer _____ kPa abs
 Range of ambient temperatures:
 Dry bulb _____ °C Wet bulb _____ °C
 Normal _____ °C
 Maximum 82 °C
 Minimum 0 °C
 Unusual conditions Dust Fumes

Single stage Single helical
 Double stage Double helical
 Epicyclic horizontal offset

Mechanical rating (1.5.16) 2268 kW @ 1800 / 10737,9 rpm
 Gear service factor (2.2.3.1) 1,46 API 613/2003 5 TH (actual)
 Full load gear unit power loss 21 kW
 Gear Unit Mechanical efficiency 98,70 %
 Rating speed Pinion 10.737,9 Gear 1.800,0 rpm
 Hardness used for
 Rating, (HB or Rc) Pinion 58 HRC Gear 58 HRC
 Tooth pitting index, "K" (2.2.4.1) (2.2.4.2)
 Allowable 2,17 Actual 2,06 MPa
 Material index number (Fig 3, Table 4) 3,03 MPa
 Bending stress number, "S_t" (2.2.5.1) (2.2.5.2)
 Pinion: Allowable 265,4 Actual 251,0 MPa
 Gear: Allowable 265,4 Actual 238,8 MPa
 Pitch line velocity 63,0 m/s
 Anticipated SPL (2.1.6) 82 dB(A) @ 1 m
 WR² referred to LS shaft 20,88 kgm²
 Breakaway torque 90 Nm @ LS Shaft
 Pinion teeth hardness range 58 - 63 HRC
 Pinion teeth hardening method CARBURIZED
 HS shaft separate hardness range _____
 Gear teeth (rim) hardness range 58 - 63 HRC
 Gear teeth hardening method CARBURIZED
 Gear hub:
 Forged cylinder Forged & Copped Fabricated
 Gear to Shaft fit method (2.5.3.2)
 Integral Keyed interference Keyless interference
 Rim attachment (2.5.3.2) FORGED GEAR WHEEL
 LS shaft hardness range HB 230 - 274
 Journal static weight loads (2.6.6.3)
 Pinion 37 / 4 kg Gear 347 / 253 kg
 Total gear unit assembled weight 1900 kg
 NOTES: _____

SPECIAL PURPOSE GEAR UNITS
API 613 FIFTH EDITION
DATA SHEET SI UNITS

Job No.	<u>41104</u>	Item No.	<u>B</u>
P.O. No.	_____	Date	_____
Requisition No.	_____		
Inquiry No.	_____		
Revision	<u>1</u>	Date	<u>06.03.2015</u> By <u>HNI</u>

■ GEAR DATA			
	Pinion	Gear	
Number of teeth	<u>29</u>	<u>173</u>	
Gear ratio	<u>5,97</u>		
Tangential load, "Wt" (2.2.4.2)	<u>25.731</u>		N
AGMA Geometry factor "J"	<u>0,52</u>	<u>0,54</u>	
Pitch diameter	<u>111,98</u>	<u>668,02</u>	mm
Outside diameter	<u>120,30</u>	<u>673,50</u>	mm
Root diameter	<u>103,05</u>	<u>656,32</u>	mm
Center groove diameter	<u>93,00</u>	<u>640,00</u>	mm
Normal pressure angle	<u>20,00</u>		deg
Normal diametral pitch	<u>7,26</u>		in ⁻¹
Helix angle	<u>24,25</u>		deg
Center distance	<u>390,00</u>		mm
Backlash min	<u>0,28</u>		mm
Net face width, "Fw"	<u>130,00</u>		mm
Pinion L/D	<u>1,74</u>		
Face overlap ratio	<u>4,86</u>		
Transverse contact ratio	<u>1,45</u>		
AGMA 6011 service factor	<u>2,87</u>		
Rating based on ANSI/AGMA 6011 with SF=1.0			
Durability Power	<u>5404</u>		kW
Strength Power	<u>4652</u>		kW
Tooth Surface Finish, Ra	<u>0,4</u>	<u>0,4</u>	µm
Tooth Generation Process	<u>Hobbing</u>	<u>Hobbing</u>	
Tooth Finishing Process	<u>Grinding</u>	<u>Grinding</u>	
Lead modification (2.2.4.6)	<input checked="" type="radio"/> Not Req'd	<input type="radio"/> Req'd	
Calculated Total Lead Mismatch			µm
■ SCUFFING DATA (2.2.6)			
Scuffing Data per ANSI/AGMA 925-A03			
Scuffing Risk (2.2.6)	<u><=5% (Low)</u>	Calculation Method	<u>AGMA925</u>
Composite surface roughness, ox	<u>0,57</u>		µm
Specific film thickness, EHL Amin	<u>2,54</u>		µm
Tooth temperature, θm	<u>80</u>		°C
Maximum contact temperature, θBmax	<u>93</u>		°C
■ MATERIALS			
Gear casing	<u>Steel</u>	Oil seals	<u>aluminium</u>
Pinion(s)	<u>18CrNiMo7-6</u>		
Gear rim(s)	<u>18CrNiMo7-6</u>		
HS Shaft	<u>Integral</u>	LS Shaft	<u>42CrMo4</u>
Redial bearings	<u>Babbitt</u>	Backing	<u>Steel</u>
Thrust bearing(s)	<u>Babbitt</u>	Backing	<u>Steel</u>
○ SHAFT END DETAIL			
<input checked="" type="checkbox"/> Gear shaft end for coupling integral flange (2.5.4.2)			
<input checked="" type="checkbox"/> Pinion shaft end for coupling integral flange (2.5.4.2)			
<input checked="" type="checkbox"/> Other :	<u>WITHOUT BOLTS</u>		

○ COUPLINGS AND GUARDS					
	Pinion	Gear			
Coupling furnished by (3.2.1)	<u>Compr. Supplier</u>	<u>Compr. Supplier</u>			
Mount coupling halves (3.2.2)	<u>Compr. Supplier</u>	<u>Compr. Supplier</u>			
Cplg. guard adapter by (3.2.3)	<u>Gear Supplier</u>	<u>Gear Supplier</u>			
Cplg. guard furnished by (3.2.3)	<u>Compr. Supplier</u>	<u>Compr. Supplier</u>			
Coupling vendor (3.2.3)					
Vendor's model number (3.2.3)					
Coupling weight on shaft, kg	<u>10,4</u>	<u>26,4</u>			
CG inboard / outboard of shaft end	<u>Outboard</u>	<u>Outboard</u>			
Hub drill template provided	<input type="checkbox"/>	<input type="checkbox"/>			
■ SHAFT END DETAIL (2.5.4.2)					
Shaft end detail specified by: <input checked="" type="radio"/> Purchaser <input type="radio"/> Gear vendor					
(Integral unless otherwise specified)					
Shaft end detail if 'otherwise' specified:					
	Pinion	Gear			
Tapered / Keyless	<input type="radio"/> <input type="checkbox"/>	<input type="radio"/> <input type="checkbox"/>			
Tapered / 1-Key	<input type="radio"/> <input type="checkbox"/>	<input type="radio"/> <input type="checkbox"/>			
Tapered / 2-Keys	<input type="radio"/> <input type="checkbox"/>	<input type="radio"/> <input type="checkbox"/>			
Cylindrical / 1-Key	<input type="radio"/> <input type="checkbox"/>	<input type="radio"/> <input type="checkbox"/>			
Cylindrical / 2-Keys	<input type="radio"/> <input type="checkbox"/>	<input type="radio"/> <input type="checkbox"/>			
Other <u>Flanged</u>	<input checked="" type="radio"/> <input type="checkbox"/>	<input checked="" type="radio"/> <input type="checkbox"/>			
Shaft diameter	<u>75,0</u>	<u>120,0</u>	mm		
(If integral flange use diameter immediately adjacent to flange)					
■ RADIAL BEARINGS					
	Pinion		Gear		
Type	TPADS /	TPADS	CYL. /	CYL.	
Diameter	<u>80 /</u>	<u>80</u>	<u>120 /</u>	<u>120</u>	mm
Length	<u>56 /</u>	<u>56</u>	<u>60 /</u>	<u>60</u>	mm
Journal velocity	<u>45,0 /</u>	<u>45,0</u>	<u>11,3 /</u>	<u>11,3</u>	m/s
Loading	<u>3,08 /</u>	<u>3,10</u>	<u>2,52 /</u>	<u>2,26</u>	N/mm ²
Clearance (min-max)					mm
Span	<u>340</u>		<u>340</u>		mm
Power loss each bearing	<u>6,3 /</u>	<u>6,3</u>	<u>0,7 /</u>	<u>0,7</u>	kW
Oil flow each bearing	<u>15,0 /</u>	<u>15,0</u>	<u>5,0 /</u>	<u>5,0</u>	l/min
■ THRUST BEARINGS					
Location			<u>OPP.CPLG.SIDE</u>		
Manufacturer	<u>FLENDER</u>		<u>FLENDER</u>		
Type	<u>NO</u>		<u>COMB.TAP.LANDS</u>		
Size			<u>BPK LEG 4"</u>		
Area			<u>5160</u>		mm ²
Loading			<u>1,35</u>		MPa
Rating			<u>1,50</u>		MPa
Int. thrust load					N
Ext. thrust load	<u>2.700</u>		<u>4.250</u>		N
Power loss each	<u>0,0</u>		<u>5,0</u>		kW
Oil flow each bearing	<u>0,0</u>		<u>15,0</u>		l/min
NOTES :					

SPECIAL PURPOSE GEAR UNITS
API 613 FIFTH EDITION
DATA SHEET SI UNITS

Job No. 41104 Item No. B
 P.O. No. _____ Date _____
 Requisition No. _____
 Inquiry No. _____
 Revision 1 Date 06.03.2015 By HNI

1 **○ LUBRICATION REQUIREMENTS**

2 Oil system furnished by (2.8.3) _____

3 Other _____ Gear vendor _____

4 Oil visc. _____ cp @ 40°C _____ cp @ 100°C (2.8.6)

5 ISO Grade _____ Load stage (2.2.6) 7,0

6

7 **■ MESH**

8 Mesh and windage power loss 2,0 KW

9 Oil flow, mesh 9,0 l/min

10

11 **■ LUBRICATION REQUIREMENTS**

12 Min. start-up oil temperature 20,0 °C

13 Normal oil inlet temperature 60,0 °C

14 Maximum oil inlet temperature 65,0 °C

15 Unit oil flow (total) 64,0 l/min

16 Unit oil pressure 2,5 bar

17 Oil visc. _____ cp @ 40°C _____ cp @ 100°C (2.8.6)

18 ISO Grade 46 Load stage (2.2.6) 7,0

19

20 **■ PIPING CONNECTIONS**

Service	No.	Size	Type
Lube oil inlet	1	1,5 in.	ANSI 150 LBS
Lube oil outlet	1	6 in.	ANSI 150 LBS
Casing drain *			
Vent	1	1,5 in.	ANSI 150 LBS
Casing purge			

27 * Casing drain is 'dead bottom' housing drain, not lube oil outlet

28 **○ MOUNTING PLATES**

29 Gear furnished with (3.3.1.1)

30 Baseplate Soleplate Subplate(s) (3.3.2.10)

31 Mounting plates(s) furnished by (3.3.1.1) _____

32 Baseplate leveling (3.3.2.3) _____

33 Baseplate with leveling pads (3.3.2.3)

34 Baseplate suitable for column mounting (3.3.2.4)

35 Vendor review of purchaser's foundation dwgs. (2.1.13)

36 Grout type (3.3.1.2.4) _____

37

38 **○ CONTRACT DATA**

39 Test data prior to shipment _____

40 Progress report (5.3.3) _____

41 Vendor sign-off of inspector checklist (4.1.1.3)

42 Information retained for 20 years (4.2.1.1) (4.2.2.6.1)

43 Technical manual (5.3.6.4)

44 PAINTING (4.4.3.1) Flender standard RAL5015 (blue)

45 Painting housing interior not allowed (2.3.1.14)

46 **○ SHIPMENT**

47 Steel rotor storage container (4.4.5) Shaft covers (4.4.4)

	Contract unit	Spares
48 Export boxing	<input type="checkbox"/>	<input type="checkbox"/>
50 Domestic boxing	<input type="checkbox"/>	<input type="checkbox"/>
51 Outdoor storage over 6 mos.	<input type="checkbox"/>	3 years indoor <input type="checkbox"/> (4.4.3.9)

1 **○ ADDITIONAL REQUIREMENTS**

2 **○ VIBRATION DETECTORS**

RADIAL (3.4.2.1) (2.7.4.5) (2.7.4.6)

Manufacturer BENTLY NEVADA Total No. 8

X-Y probes pinion bearings Coupling end Blind end

X-Y probes gear bearings Coupling end Blind end

Other _____

AXIAL (3.4.2.1) (2.7.4.5) (2.7.4.6)

Manufacturer BENTLY NEVADA Total No. 2

Dual probes at each thrust bearing

Single probe any shaft without thrust bearing

Other _____

ONE EVENT PER REVOLUTION PROBE (2.7.4.5) (2.7.4.6)

Manufacturer BENTLY NEVADA Total No. 2

One on input shaft One on output shaft

Other _____

ACCELEROMETER (3.4.2.1) (2.7.4.5) (2.7.4.6)

Manufacturer BENTLY NEVADA No. required 2

Pinion coupling end Gear coupling end

Other _____

3 **○ TEMPERATURE DETECTORS**

Dial type thermometers (3.4.2.7) _____

Type brg. temp. sensors (3.4.2.7) (2.7.1.3) PT100

RTD Thermocouple / Simplex Duplex

Calibration Yes

HSALS bearings no. sensors each 2 / 2

Thrust number of sensing elements each face 2

4 **○ OTHER VIBRATION AND TEMPERATURE**

(3.4.2.5) (3.4.2.6) Other Gear vendor

Oscillator demodulator supplied by

Vibration monitor supplied by

Vibration shutdown delay time _____ seconds

Temperature monitor supplied by

Oscillator demodulator J-box by

Temp. sensor termination J-box by

J-box type _____ Mount _____

5 **○ MISCELLANEOUS**

Undamped critical analysis report (2.6.2.1)

w/ dampd rotr respns anlysis rpt (2.6.2.4.3) (2.6.2.6)

Torsional analysis by (2.6.5.2) Gear vendor Other

Spare set of gear rotors (4.3.2.4)

Gear case furnished with inlet purge connection (2.4.3)

Orientation of oil inlet & drain conns. (2.4.6) _____

Filter breather location (2.3.1.12) Prov. on upper casing

Torsional device provisions (2.5.4.5) _____

Rotor vertical storage provisions (2.5.4.8) _____

Rotor vertical storage fixture(s) (3.6.2) _____

Vendor service rep. on site (2.1.13)

**SPECIAL PURPOSE GEAR UNITS
API 613 FIFTH EDITION
DATA SHEET SI UNITS**

Job No.	41104	Item No.	B
P.O. No.		Date	
Requisition No.			
Inquiry No.			
Revision	1	Date	06.03.2015 By HNI

O INSPECTIONS AND TESTS (4.1)				
<input type="checkbox"/> Advance notice of witness testing required (4.1.3)				
Number calendar days _____				
	Req'd	Witness	Observe	Test Log
6	Shop Inspection (4.1.1)	<input type="checkbox"/>	<input type="checkbox"/>	<input type="checkbox"/>
7	Cleanliness Inspection (4.2.3.1)	<input type="checkbox"/>	<input type="checkbox"/>	<input type="checkbox"/>
8	Hardness Verification (4.2.3.3)	<input checked="" type="checkbox"/>	<input type="checkbox"/>	<input checked="" type="checkbox"/>
9	Dismantle-reassembly (4.3.2.3.1)	<input checked="" type="checkbox"/>	<input type="checkbox"/>	<input type="checkbox"/>
10	Contact Check (2.5.2.2)	<input checked="" type="checkbox"/>	<input type="checkbox"/>	<input type="checkbox"/>
11	Contact Check Tape Lift (2.5.2.2)	<input checked="" type="checkbox"/>	<input type="checkbox"/>	<input checked="" type="checkbox"/>
12	Gear accuracy check (2.5.2.1)	<input checked="" type="checkbox"/>	<input type="checkbox"/>	<input type="checkbox"/>
13	Double helical axial stability (2.5.2.3)	<input checked="" type="checkbox"/>	<input type="checkbox"/>	<input checked="" type="checkbox"/>
14	Special testing integral forged gears (2.5.3.3)			
15	(testing per mutual agreement)	<input type="checkbox"/>	<input type="checkbox"/>	<input type="checkbox"/>
16	Residual unbalance check (2.6.6.2)	<input checked="" type="checkbox"/>	<input type="checkbox"/>	<input checked="" type="checkbox"/>
17	Mechanical Run Test (Main) (4.3.2)	<input checked="" type="checkbox"/>	<input type="checkbox"/>	<input checked="" type="checkbox"/>
18	Mechanical Run Test (Spare) (4.3.2.4)	<input type="checkbox"/>	<input type="checkbox"/>	<input type="checkbox"/>
19	Add'l. Mechanical Tests (4.3.2.2.16)	<input type="checkbox"/>	<input type="checkbox"/>	<input type="checkbox"/>
20	Part or Full Load And Full Speed			
21	Test (4.3.3.1)	<input type="checkbox"/>	<input type="checkbox"/>	<input type="checkbox"/>
22	Full torque, reduced speed (4.3.3.2)	<input type="checkbox"/>	<input type="checkbox"/>	<input type="checkbox"/>
23	Full Torque Static Test (4.3.3.3)	<input type="checkbox"/>	<input type="checkbox"/>	<input type="checkbox"/>
24	Back-To-Back Locked Torque			
25	Test (4.3.3.4)	<input type="checkbox"/>	<input type="checkbox"/>	<input type="checkbox"/>
26	Sound Level Test (4.3.3.5)	<input checked="" type="checkbox"/>	<input type="checkbox"/>	<input checked="" type="checkbox"/>
27	Additional gear tooth test (4.2.2.8)	<input type="checkbox"/>	<input type="checkbox"/>	<input type="checkbox"/>
28	Use shop Lube System	<input checked="" type="checkbox"/>	<input type="checkbox"/>	<input type="checkbox"/>
29	Use job lube system	<input type="checkbox"/>	<input type="checkbox"/>	<input type="checkbox"/>
30	Use shop Vibration Probes, Etc.	<input type="checkbox"/>	<input type="checkbox"/>	<input type="checkbox"/>
31	Use job Vibration Probes, Etc.	<input checked="" type="checkbox"/>	<input type="checkbox"/>	<input type="checkbox"/>
32	Final Assembly, Maintenance &			
33	Running Clearance (4.2.1.1.e)	<input checked="" type="checkbox"/>	<input type="checkbox"/>	<input checked="" type="checkbox"/>
34	Oil System Cleanliness (4.2.3.2)	<input type="checkbox"/>	<input type="checkbox"/>	<input type="checkbox"/>
35	Oil System-Casing Joint			
36	Tightness (4.3.2.1.4)	<input type="checkbox"/>	<input type="checkbox"/>	<input type="checkbox"/>
37	Warning And Protection			
38	Devices (4.3.2.1.5)	<input type="checkbox"/>	<input type="checkbox"/>	<input type="checkbox"/>
39	Seismic Vibration Data (4.3.2.2.3)	<input type="checkbox"/>	<input type="checkbox"/>	<input type="checkbox"/>
40	Vibration, Phase Plots (4.3.2.2.12)	<input checked="" type="checkbox"/>	<input type="checkbox"/>	<input checked="" type="checkbox"/>
41	Oil Inlet Range test (4.3.2.2.13)	<input type="checkbox"/>	<input type="checkbox"/>	<input type="checkbox"/>
42	Tape recorded Vibration Data	<input checked="" type="checkbox"/>	<input type="checkbox"/>	<input checked="" type="checkbox"/>
43	(4.3.2.2.14) (4.3.2.2.15)	<input type="checkbox"/>	Purchaser copy	
44	NON-DESTRUCTIVE TESTING (4.2.1.2) (4.2.2.1)			
	Surface	Sub surface		Log
46	<input type="checkbox"/> Casing	<input type="checkbox"/>	<input type="checkbox"/>	<input type="checkbox"/>
47	<input checked="" type="checkbox"/> Rot. Elmts.	<input checked="" type="checkbox"/>	<input checked="" type="checkbox"/>	<input checked="" type="checkbox"/>
48	<input checked="" type="checkbox"/> Bearings	<input checked="" type="checkbox"/>	<input checked="" type="checkbox"/>	<input checked="" type="checkbox"/>
49	<input type="checkbox"/> Other :	<input type="checkbox"/>	<input type="checkbox"/>	<input type="checkbox"/>
50	(Specify)			

NOTES :

During start-up, gears can exhibit a transient spike reading of vibration levels that will exceed shutdown settings. Therefore a trip multiplier is recommended in the control system.

Mechanical running test duration 4 hours including

- Shaft vibration record using job vibration probes if ordered
- Bearings temperature records
- Casing vibration measurement
- Sound level pressure measurement
- Power losses measurement at oil outlet
- Performed with oil ISO VG 32

Oil flow requirement and power losses are calculated values only, add normal safety margins for sizing heat exchangers.

PRELIMINARY MASS ELASTIC DATA

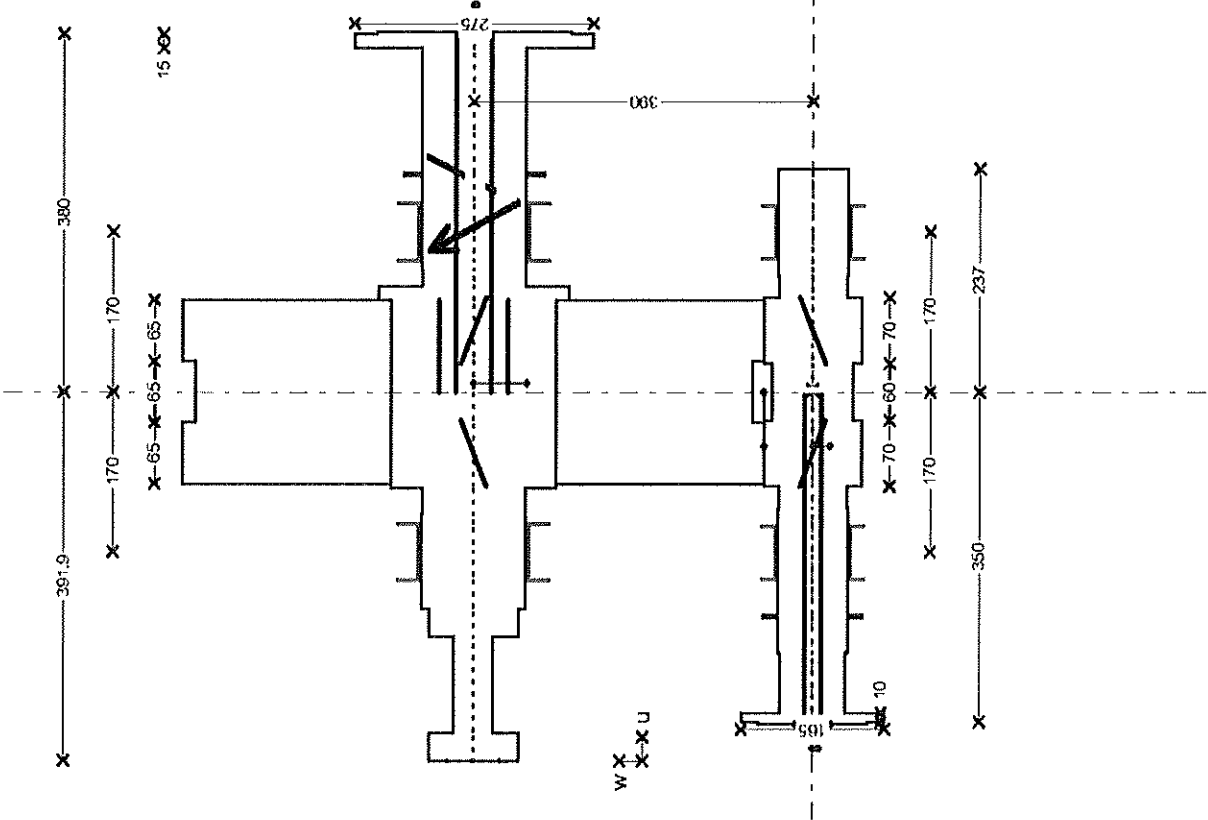

Customer : Siemens AG Duisburg
 Destination : Khursaniyah Al Fadhihi
 Purchaser order :
 F-G job number : D 4:10481 OL
 Type and serial N° : TX40/5C

Power rating : 1620 kW
 Service factor : AP1613.03 >=1,4
 Input speed : 1800 rpm
 Output speed : 10737,9 rpm
 Speed ratio : 5,96

Weight HSS : 30,5 kg
 Weight pos. from teeth middle HSS : 57,5 mm
 Inertia HSS : 0,038 Kg.m²
 Stiffness HSS : 1,11 MN/mrd
 Bearing type 1 : Tilting pads 80 x 56
 Bearing type 2 : Tilting pads 80 x 56
 Add. weight on brg. side 1 : 10,4 kg

Weight LSS : 574,3 kg
 Weight pos. from teeth middle LSS : 9 mm
 Inertia LSS : 28,526 Kg.m²
 Stiffness LSS : 6,5 MN/mrd
 Bearing type 4 : Cylindrical 120 x 60
 Bearing type 3 : Cylindrical 120 x 60
 Add. weight on brg. side 4 : 26,4 kg

Positive direction of external

APPAREIL.xls _ Edition du :06.03.2015
 1/1

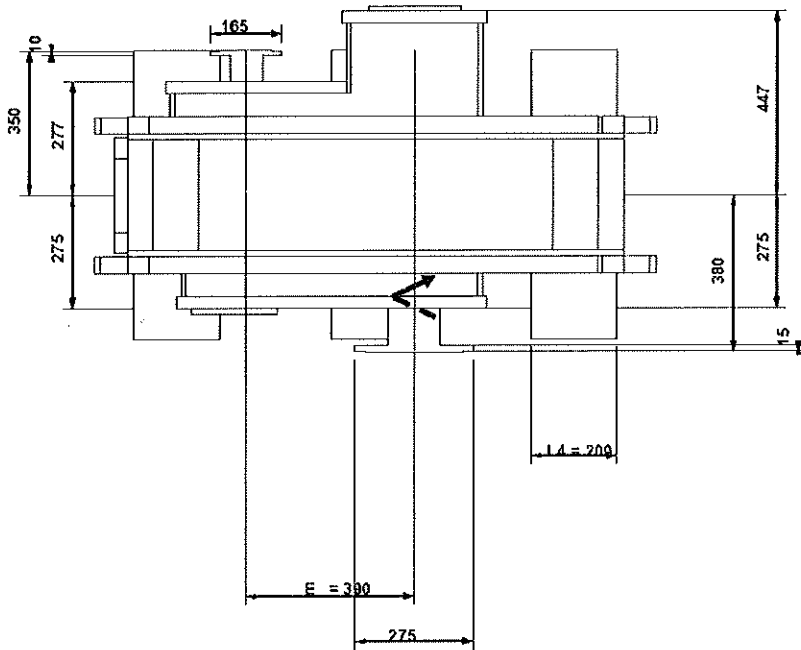
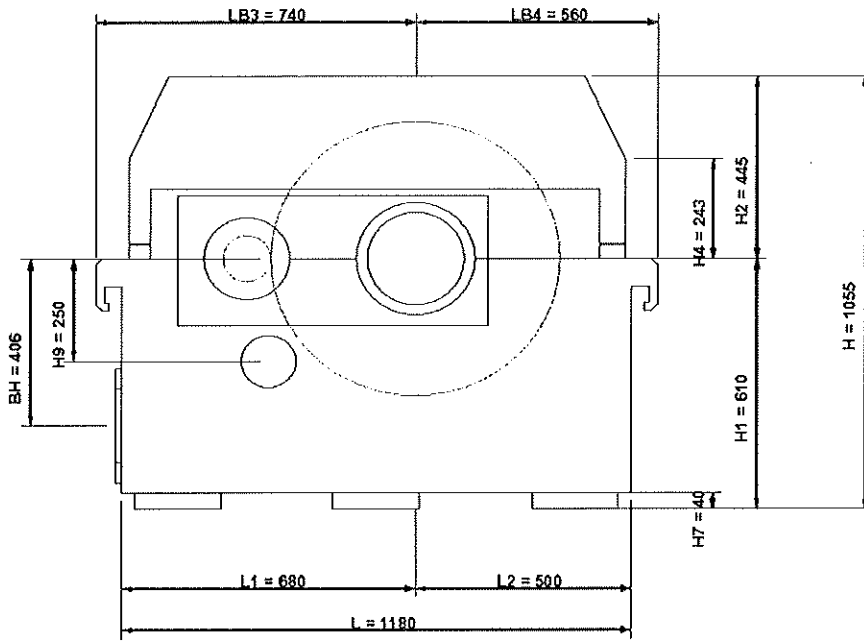

ADDITIONAL TECHNICAL DATASHEET		Job No. <u>41104</u> Item No. <u>B</u>																																			
		P.O. No. _____ Date _____																																			
		Requisition No. _____																																			
		Inquiry No. _____																																			
		Revision <u>1</u> Date <u>06.03.2015</u> By <u>HNI</u>																																			
<input checked="" type="checkbox"/> ADDITIONAL GEAR DATA		<input type="checkbox"/> TURNING GEAR (Dimensioning is preliminary I)																																			
<i>Efficiency</i>		<i>Calculation results</i>																																			
<table border="1" style="width:100%; border-collapse: collapse;"> <thead> <tr> <th>Percent of rated power</th> <th>Efficiency</th> </tr> </thead> <tbody> <tr> <td>100%</td> <td style="text-align: center;">98,70</td> </tr> <tr> <td>75%</td> <td style="text-align: center;">98,66</td> </tr> <tr> <td>50%</td> <td style="text-align: center;">98,38</td> </tr> <tr> <td>25%</td> <td style="text-align: center;">97,42</td> </tr> <tr> <td>10%</td> <td style="text-align: center;">87,68</td> </tr> </tbody> </table>		Percent of rated power	Efficiency	100%	98,70	75%	98,66	50%	98,38	25%	97,42	10%	87,68	Required turning speed _____ rpm Actual turning speed _____ rpm Required breakaway torque _____ Nm Actual breakaway torque _____ Nm Actual maximum torque _____ Nm Actual acceleration time _____ s																							
Percent of rated power	Efficiency																																				
100%	98,70																																				
75%	98,66																																				
50%	98,38																																				
25%	97,42																																				
10%	87,68																																				
<i>Losses</i>		<i>Motor</i>																																			
Power loss at no load _____ kW Heat rejection _____ kcal/h		Supplier _____ Power _____ kW Voltage _____ V Frequency _____ Hz Speed _____ rpm Electric standard _____																																			
<input type="checkbox"/> PUMP DETAILS (Dimensioning is preliminary I)		<i>Turning gear</i>																																			
Design : _____ Speed : _____ rpm Oil flow : _____ l/min Oil pressure : _____ bar NPSH : _____ m Safety valve : _____ Driving method : _____ Material : _____ Flanges : _____ Testing : _____ Furniture of ATEX certificate : _____		Type _____ Ratio _____																																			
		<i>Clutch</i>																																			
		Type _____ Max. allowable torque _____ Nm																																			
		<i>Miscellaneous</i>																																			
		Starting device _____ Switch details _____																																			
<input checked="" type="checkbox"/> INSTRUMENTATION PACKAGE																																					
<i>Thermometer</i>		<i>Thermoelements</i>																																			
<table border="1" style="width:100%; border-collapse: collapse;"> <thead> <tr> <th></th> <th>Bearing</th> <th>Thrust bearing</th> <th>Oil inlet/outlet</th> </tr> </thead> <tbody> <tr> <td>Qty</td> <td></td> <td></td> <td></td> </tr> <tr> <td>Type</td> <td></td> <td></td> <td></td> </tr> </tbody> </table>			Bearing	Thrust bearing	Oil inlet/outlet	Qty				Type				<table border="1" style="width:100%; border-collapse: collapse;"> <thead> <tr> <th></th> <th>Bearing</th> <th>Thrust bearing</th> <th>Oil inlet/outlet</th> </tr> </thead> <tbody> <tr> <td>Type</td> <td>DUPLEX 2x3F</td> <td>DUPLEX 2x3F</td> <td></td> </tr> <tr> <td>Classification</td> <td>IEC60751</td> <td>IEC60751</td> <td></td> </tr> <tr> <td>Removable from the outside</td> <td>NO</td> <td>NO</td> <td></td> </tr> <tr> <td>ATEX</td> <td>ATEX Eexia</td> <td>ATEX Eexia</td> <td></td> </tr> </tbody> </table>		Bearing	Thrust bearing	Oil inlet/outlet	Type	DUPLEX 2x3F	DUPLEX 2x3F		Classification	IEC60751	IEC60751		Removable from the outside	NO	NO		ATEX	ATEX Eexia	ATEX Eexia				
	Bearing	Thrust bearing	Oil inlet/outlet																																		
Qty																																					
Type																																					
	Bearing	Thrust bearing	Oil inlet/outlet																																		
Type	DUPLEX 2x3F	DUPLEX 2x3F																																			
Classification	IEC60751	IEC60751																																			
Removable from the outside	NO	NO																																			
ATEX	ATEX Eexia	ATEX Eexia																																			
<i>Shaft vibrations</i>																																					
<table border="1" style="width:100%; border-collapse: collapse;"> <thead> <tr> <th></th> <th>Radial</th> <th>Axial</th> <th>Keyphasor</th> <th>Accelerometer</th> </tr> </thead> <tbody> <tr> <td>Type</td> <td>B.N. 3300 XL 8mm Sys. 9M</td> <td>HS No LS BENTLY NEVADA 3300 XL 8mm Sys. 9M</td> <td>B.N. 3300 XL 8mm Sys. 9M</td> <td>ACCELEROMETER BENTLY</td> </tr> <tr> <td>Probe</td> <td>Yes</td> <td>HS No LS Yes</td> <td>Yes</td> <td></td> </tr> <tr> <td>Proximitior</td> <td>Yes</td> <td>HS No LS Yes</td> <td>Yes</td> <td style="background-color: #cccccc;"></td> </tr> <tr> <td>Probe holder</td> <td>Yes</td> <td>HS No LS Yes</td> <td>Yes</td> <td style="background-color: #cccccc;"></td> </tr> <tr> <td>Connection head</td> <td>Yes</td> <td>HS No LS Yes</td> <td>Yes</td> <td style="background-color: #cccccc;"></td> </tr> <tr> <td>mounting kit</td> <td style="background-color: #cccccc;"></td> <td style="background-color: #cccccc;"></td> <td style="background-color: #cccccc;"></td> <td>Yes</td> </tr> </tbody> </table>				Radial	Axial	Keyphasor	Accelerometer	Type	B.N. 3300 XL 8mm Sys. 9M	HS No LS BENTLY NEVADA 3300 XL 8mm Sys. 9M	B.N. 3300 XL 8mm Sys. 9M	ACCELEROMETER BENTLY	Probe	Yes	HS No LS Yes	Yes		Proximitior	Yes	HS No LS Yes	Yes		Probe holder	Yes	HS No LS Yes	Yes		Connection head	Yes	HS No LS Yes	Yes		mounting kit				Yes
	Radial	Axial	Keyphasor	Accelerometer																																	
Type	B.N. 3300 XL 8mm Sys. 9M	HS No LS BENTLY NEVADA 3300 XL 8mm Sys. 9M	B.N. 3300 XL 8mm Sys. 9M	ACCELEROMETER BENTLY																																	
Probe	Yes	HS No LS Yes	Yes																																		
Proximitior	Yes	HS No LS Yes	Yes																																		
Probe holder	Yes	HS No LS Yes	Yes																																		
Connection head	Yes	HS No LS Yes	Yes																																		
mounting kit				Yes																																	
<i>Junction box(es)</i>		<i>Miscellaneous</i>																																			
Qty _____ 0 Manufacturer _____ Material _____ ATEX _____ None		Identification <input checked="" type="checkbox"/> wire <input checked="" type="checkbox"/> conduit <input type="checkbox"/> junction box Conduit type _____ Transmitter type _____ Qty _____ Terminal block type _____ Qty _____																																			

Commercial Conditions

- Prices are quoted FCA Illkirch-Graffenstaden following Incoterms 2010 including packing cat 1A of SEI, 1999 issue, ind. 2.
- Progress payments : 100% at delivery.
- This quotation is subjected to the Flender Graffenstaden Standard Terms and Conditions of Sales and valid for acceptance until the 15th of July 2015.
- Where approval of drawings is required, approval must be in line with the document schedule.
- Warranty period is 18 months of operation or 24 months after delivery whichever occurs first. We recommend the supervision of our engineer for the commissioning.
- Flender-Graffenstaden SAS shall not be obligated to fulfill this agreement if such fulfillment is prevented by any impediments arising out of national or international foreign trade or customs requirements or any embargoes or other sanctions.

Applicable documents for the quotation (available on demands)

Documents schedule,
Quality plan
Painting standard,
Standard Terms and Conditions of Sales

We thank you for the opportunity of quoting and look forward to the pleasure of serving you.

Very truly yours,

N. HOST
(Project Engineer)



Y. FRIEDMANN
(Sales Manager)



Generated with CAMEC V 4.9.5 26 Feb 2014

**** "This quotation is subject to confidentiality. Information thereof may not be shared with or forwarded to any third parties!"**