

Document – No. **AL\_5838046**

Index **a**

State Released

Type of document Specification

Number of pages 31

## Coupling System

---

### L-4561 KHYL

---

<b>Created</b> (first version)		<b>Checked</b> (current index)		<b>Released</b> (current index)	
Name	Date	Name	Date	Name	Date
urbrob	26.03.2024	morchr	26.07.2024	morchr	26.07.2024

Any unauthorized copying, alteration, distribution, transmission, display or other use of this material without prior written permission is expressly prohibited. Information contained herein may be changed or updated without notice.

## Table of Revision

Index	Modification	Date	Author	Checked	Released
–	First Version	13.05.2024	R. Urban	Chr. Morath	M. Basaras
a	<ul style="list-style-type: none"> <li>• Chapter 3.2.2.3.1: Update of vertical pitch angle</li> <li>• Chapter 3.2.2.5.1 and 3.2.2.5.2: Document Number for weightlist added</li> <li>• Chapter 3.2.3.1: Requirement for position of pneumatic interface added</li> <li>• Chapter 3.2.4.6.1: Update of Table 3</li> <li>• Chapter 4.1.1 and 4.1.2: Figures updated</li> </ul>	26.07.2024	R. Urban	Chr. Morath	Chr. Morath
b					
c					

# Index of Contents

<b>Table of Revision</b> .....	<b>2</b>
<b>Index of Contents</b> .....	<b>3</b>
<b>List of Figure</b> .....	<b>6</b>
<b>List of Tables</b> .....	<b>6</b>
<b>1 Introduction</b> .....	<b>8</b>
1.1 General Information .....	8
1.2 Unit Configuration .....	8
1.3 Validity of the Specification .....	8
1.4 System Responsibility.....	8
1.5 Acronyms and Abbreviations .....	8
1.6 Applicable Specifications .....	8
1.7 Applicable Documents and Appendices.....	9
1.8 Contract Language .....	9
1.9 Confidentiality .....	9
1.10 Duty Cycles and Service Life of the Vehicle.....	9
1.11 Time schedule .....	9
<b>2 Standards and Regulations</b> .....	<b>9</b>
2.1 Applicable Laws and Standards.....	9
2.2 General List of Standards and Regulations.....	9
<b>3 Technical Requirements and Properties</b> .....	<b>10</b>
3.1 General Requirements.....	10
3.1.1 Sound-related Requirements and Vibration .....	10
3.1.2 Climatic and Environmental Conditions.....	10
3.1.2.1 Materials and Substances Subject to Special Restrictions .....	10
3.1.2.2 Supplier Declaration.....	10
3.1.3 Watertightness.....	10
3.1.4 Loading / Design Loads / Force .....	10
3.1.5 Fire Protection .....	10
3.1.5.1 Fire Protection Requirements of Materials .....	10
3.1.5.2 Electrical Components .....	10

3.1.5.3	Fire Barrier .....	10
3.1.5.4	Fire detection system .....	10
3.1.5.5	Fire extinguisher .....	11
3.1.5.6	Fire Load Calculation .....	11
3.1.5.7	Fire Risk Analysis.....	11
3.1.6	Adhesive Bonding .....	11
3.1.7	Welding Assemblies.....	11
3.1.8	Maintainability and Maintenance .....	11
3.1.8.1	Cleaning.....	11
3.1.8.2	Vandalism .....	11
3.1.9	Ergonomics.....	11
3.1.10	Notes on Mechanical Components .....	11
3.1.11	Customer Requirements .....	11
3.2	System-specific Requirements and Properties.....	15
3.2.1	Functionality.....	15
3.2.2	Mechanical Requirements.....	17
3.2.2.1	General Notes for mechanical components.....	17
3.2.2.2	Weight.....	17
3.2.2.3	Dimensions and tolerances .....	17
3.2.2.4	Materials / Chemicals.....	19
3.2.2.5	Strength and energy absorption .....	19
3.2.2.6	Surface / Corrosion .....	22
3.2.2.7	Identification / Marking / Type Plates / Pictograms .....	22
3.2.2.8	Locking Concept .....	22
3.2.2.9	Installation Instructions.....	22
3.2.3	Pneumatic Requirements.....	22
3.2.3.1	AFC .....	22
3.2.3.2	SPC .....	23
3.2.4	Electrical Requirements .....	23
3.2.4.1	General Notes for electric components .....	23
3.2.4.2	Energy Supply.....	23

3.2.4.3	EMC.....	23
3.2.4.4	Earthing .....	24
3.2.4.5	Power Consumption.....	24
3.2.4.6	Cabling and Electrical Connections.....	24
3.2.4.7	Communication interface.....	26
3.2.5	Software Requirements .....	26
3.2.6	Diagnosis and Failure Behaviour .....	26
<b>4</b>	<b>Interfaces .....</b>	<b>26</b>
4.1	Mechanical Interfaces.....	26
4.1.1	AFC .....	26
4.1.2	SPC .....	26
4.2	Pneumatic Interfaces .....	27
4.3	Electrical Interfaces .....	27
4.4	Software Interfaces.....	27
<b>5</b>	<b>RAM/LCC, Special Tools, Spare Parts and Maintenance Requirements .....</b>	<b>27</b>
5.1	Risk analysis.....	27
5.2	Requirement management .....	27
5.3	Development Process.....	28
5.4	Verification and validation .....	28
5.5	System integration .....	28
5.6	Lifecycle management.....	28
5.7	Documentation .....	28
5.8	Reliability .....	28
5.9	Availability .....	28
5.10	Life Cycle Cost (LCC) .....	28
5.11	Maintainability.....	28
5.12	Accessibility .....	28
5.13	Spare Parts.....	28
5.14	Special Tools .....	29
5.15	Maintenance Justification.....	29
<b>6</b>	<b>Safety .....</b>	<b>29</b>

<b>7</b>	<b>Tests and Acceptances</b> .....	<b>29</b>
7.1	Inspections and Test Schedule .....	29
7.2	Test Certificates and Test Schedule .....	29
7.3	Pre FAI .....	29
7.4	First Article Inspection .....	30
7.5	Type Test .....	30
7.6	Series Test .....	30
7.7	Acceptance.....	30
<b>8</b>	<b>Documentation</b> .....	<b>30</b>
8.1	User Documentation .....	30
8.2	Engineering Documentation.....	30
8.2.1	Installation instructions.....	30
8.3	Configuration Management.....	30
<b>9</b>	<b>Training and Support</b> .....	<b>30</b>
<b>10</b>	<b>Scope of Delivery</b> .....	<b>31</b>
10.1	Scope of delivery - Quotation Phase.....	31
10.2	Scope of Supply .....	31

## List of Figure

Figure 1:	schema of train configuration.....	8
Figure 2:	preliminary design space for centering device (top: front view, bottom: side view).....	16
Figure 3:	Dimensions of the front coupler .....	17
Figure 4:	preliminary Mechanical Interface AFC .....	26
Figure 5:	preliminary Mechanical Interface SPC .....	27

## List of Tables

Table 1:	preliminary dimensions of the front coupler.....	18
Table 2:	preliminary dimensions of the SPC .....	19
Table 3:	preliminary AFC signals .....	25
Table 4:	Scope of delivery for quotation phase.....	31

Table 5: Scope of Supply ..... 31

# 1 Introduction

## 1.1 General Information

The aim of this specification is to specify an automatic front coupler (AFC) as well as a semi-permanent coupler (SPC) between two cars for a new metro-rail vehicle. Each vehicle is equipped with two AFC and SPC.

This specification summarises the general technical conditions of the AFC and SPC of the new metro-rail vehicle. If individual chapters of this specification describe requirements that contradict an optimal design of the design of the AFC and SPC, the supplier (SU) must submit alternative proposals stating the reasons as part of a supplementary offer.

## 1.2 Unit Configuration

The scope of delivery are twenty-five (25) vehicles in total, consisting of 3 (three) coaches/cars per train (EMU).

See general technical specification [V1] for further information, including overall measurements and layout in «Typenbild».

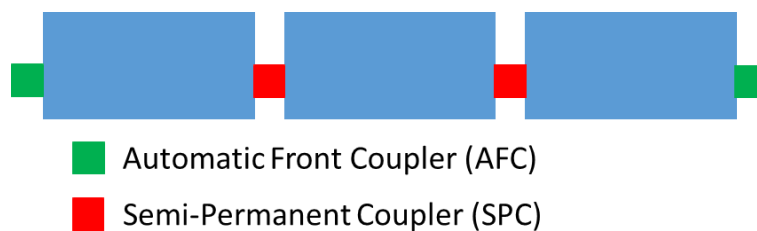

Figure 1: schema of train configuration

## 1.3 Validity of the Specification

See general technical specification [V1]

## 1.4 System Responsibility

See general technical specification [V1]

## 1.5 Acronyms and Abbreviations

See general technical specification [V1]

AFC            Automatic Front Coupler

SPC            Semi-Permanent Coupler

## 1.6 Applicable Specifications

See general technical specification [V1]



## 1.7 Applicable Documents and Appendices

[V1]	AL_5468012	General Technical Specification
[V2]	AL_5460262	General RAM / LCC Specification
[V3]	AL_5546940	Vehicle Type Drawing
[V4]	AL_5896825	CbC – Coupling System

## 1.8 Contract Language

See general technical specification [V1]

## 1.9 Confidentiality

See general technical specification [V1]

## 1.10 Duty Cycles and Service Life of the Vehicle

See general technical specification [V1]

## 1.11 Time schedule

See general technical specification [V1]

# 2 Standards and Regulations

## 2.1 Applicable Laws and Standards

See general technical specification [V1]

## 2.2 General List of Standards and Regulations

For generally applicable standards and regulations see General Technical Specification [V1]

System specific Standards and Regulations are listed below:

[N1]	EN 12663-1:2015	Railway applications - Structural requirements of railway vehicle bodies - Part 1: Locomotives and passenger rolling stock (and alternative method for freight wagons)
[N2]	EN 15227:2020	Railway applications - Crashworthiness requirements for rail vehicles
[N3]	EN 16019:2014	Railway applications - Automatic coupler - Performance requirements, specific interface geometry and test method
[N4]	EN 50155:2021	Railway applications - Rolling stock - Electronic equipment

## **3 Technical Requirements and Properties**

### **3.1 General Requirements**

#### **3.1.1 Sound-related Requirements and Vibration**

See general technical specification [V1]

The front coupler must not produce vibration, rattling or wind noise at any speed of the train. The front coupler is designed in such a way that the incidence and transfer of vibrations to the car body are minimized in driving mode. This applies to both uncoupled and coupled configurations. In addition to the natural vibrations in the vertical and lateral directions, the longitudinal dynamics of the train are also optimized as a train set (multiple unit) in terms of ride comfort.

#### **3.1.2 Climatic and Environmental Conditions**

##### **3.1.2.1 Materials and Substances Subject to Special Restrictions**

See general technical specification [V1]

##### **3.1.2.2 Supplier Declaration**

See general technical specification [V1]

#### **3.1.3 Watertightness**

See general technical specification [V1]

Degree of protection provided by enclosures for electrical components: IP65

#### **3.1.4 Loading / Design Loads / Force**

See general technical specification [V1] and chapter 3.2.2.5.

The AFC and SPC shall be able to withstand the fatigue load taken under all the operational conditions during the vehicle designed lifetime.

#### **3.1.5 Fire Protection**

See general technical specification [V1]

##### **3.1.5.1 Fire Protection Requirements of Materials**

See general technical specification [V1]

##### **3.1.5.2 Electrical Components**

See general technical specification [V1]

##### **3.1.5.3 Fire Barrier**

See general technical specification [V1]

##### **3.1.5.4 Fire detection system**

See general technical specification [V1]

#### **3.1.5.5 Fire extinguisher**

See general technical specification [V1]

#### **3.1.5.6 Fire Load Calculation**

See general technical specification [V1]

#### **3.1.5.7 Fire Risk Analysis**

See general technical specification [V1]

#### **3.1.6 Adhesive Bonding**

See general technical specification [V1]

#### **3.1.7 Welding Assemblies**

See general technical specification [V1]

#### **3.1.8 Maintainability and Maintenance**

See general technical specification [V1]

##### **3.1.8.1 Cleaning**

See general technical specification [V1]

##### **3.1.8.2 Vandalism**

See general technical specification [V1]

#### **3.1.9 Ergonomics**

See general technical specification [V1]

#### **3.1.10 Notes on Mechanical Components**

Refer to chapter 3.2.2.1.

#### **3.1.11 Customer Requirements**

[2.14/ 1839267]

Couplers are categorized to two types, automatic coupler and semi-permanent coupler. The design and materials used for couplers shall take into account: when the vehicle is under normal operation, maintenance and during operating, it shall be able to withstand the fatigue load taken under all the operational conditions during the vehicle designed lifetime.

[2.14/ 1839268]

During the vehicle designed lifetime, under the load equivalent to W4 load, any partial deformation shall not exceed the prescribed allowable deformation, fatigue cracks or any other form of fatigue damage. During the vehicle designed lifetime, under the dynamic load of traction or brake in normal operation, the coupler shall not have cracks or fatigue damage.

[2.14/ 1839269]

The buffers of automatic couplers and semi-permanent couplers shall include energy absorption device to absorb the excessive energy which is higher than the normal operation condition generated at the impact. The design of coupler buffer/energy absorption device shall absorb the movement between vehicles due to normal vibration and traction. The buffers shall be able to maintain two trains running at the maximum coupling speed without damage. The strength of buffers shall ensure that no damage occurs under the impact of the coupling speed.

[2.14/ 1839270]

For the coupler, the Contractor shall submit the design method, functions, list of the relevant design criteria, and the electrical, mechanical drawings and relevant documents for the Employer's review and approval.

[2.14.(1).A./ 1839272]

Both front and rear ends of the train shall be equipped with the automatic couplers. That said coupler shall be fitted with the functions of mechanical, pneumatic and electrical auto coupling and auto decoupling.

[2.14.(1).B./ 1839273]

The automatic coupler shall perform coupling and decoupling without manual alignment at the wayside when the train is on the minimum curve of main line or on any line in the depot. During the coupling and decoupling, the coupler shall not cause any damage to the mechanical, electrical and pneumatic devices.

[2.14.(1).C./ 1839274]

The automatic coupler shall be fitted with the manual decoupling device, automatic centering device and energy absorption device to ensure safety and convenience in use. The manual decoupling lever shall be attached to the side of the vehicle, so that the operating staff can decouple without standing between two cars to ensure safety and convenience in use.

[2.14.(1).D./ 1839275]

The automatic coupler shall have adequate swing space in vertical and horizontal directions to allow the train to move normally on this route without the coupler clashing with the underframe, while the most severe S-type reverse curve, vertical curve and the height difference between cars of this project occur simultaneously.

[2.14.(1).E./ 1839276]

The electrical and pneumatic connectors of the automatic coupler shall be able to be coupled or decoupled manually. There should be a weather resistant protection cover, which can be closed automatically upon decoupling and can be opened automatically upon coupling to prevent water and dust infiltration. The train wire shall be ended in the weather resistant junction box behind the electrical connector and be connected to the cable of the electrical connector by the weather resistant, anti-corrosion quick connector.

[2.14.(1).F./ 1839277]

The electrical connector shall have enough number of silver-plated connection points, in order to provide the power to rescue failed trains. The application of electrical connectors shall include the operation/monitor function of emergency brake, entrance door open/close, and relevant safety systems for normal train to control the failed train, and at least include 10% of spare amount (the spare amount is calculated in accordance with actual required number of connection points after the final design is reviewed). The electrical connectors shall comply with IEC 60077 and IEC

60571/EN 50155. The Contractor shall submit the design, calculation for number of connection points and relevant documents for the Employer's review and approval.

[2.14.(2).A./ 1839279]

In addition to the automatic couplers equipped at the car ends as prescribed in Section 2.14.(1).A of this Specification, the Contractor shall equip the semi-permanent couplers at the car ends of the remaining cars for coupling.

[2.14.(2).B./ 1839280]

The semi-permanent couplers shall operate normally on the main line and in the depot.

[2.14.(3).A./ 1839282]

Under the normal operating condition, the coupling and decoupling between all cars shall be performed in the maintenance depot. When a normal train is used to push or pull a failed train, the coupling operation of its automatic couplers shall be able to be done on the main line or any place in the depot.

[2.14.(3).B./ 1839283]

The coupling and decoupling of automatic couplers shall be completed automatically by the working personnel in the car. The automatic coupler shall be designed to allow one person to operate alone to complete the coupling and decoupling operation. The Contractor shall provide the coupling and decoupling methods of couplers for the scenario of failed automatic coupling system, and submit the relevant documents for the Employer's review and approval.

[2.14.(3).C./ 1839284]

The electrical coupling of all couplers shall include the vehicle earthing and protection earthing, and there shall be an earthing wire connected between the coupler and the carbody.

[2.14.(3).D./ 1839285]

When the coupler is decoupled during the moving of train, it shall have the emergency braking function. The relevant design and data shall be submitted for review and approval.

[2.14.(3).E./ 1839286]

Automatic couplers and semi-permanent couplers shall be equipped with the same characteristics on compression, extension stiffness and damping, in order to minimize the impact between vehicles when the train moves forward and brakes.

[2.14.(3).F./ 1839287]

The couplers shall be equipped with sufficient flexibility to absorb the greatest impact force generated by the train. When the couplers are damaged, they shall be easily replaceable without affecting the characteristics of the anticlimber in case of collision.

[2.14.(3).G./ 1839288]

During the operation of automatic coupling, an electrically detected signal shall be provided to confirm the completion of mechanical coupling.

[2.9.(4).B.a./ 1839092]

When the front side of the train collides with a completely rigid, fixed surface at the speed of 5 km/hr, the vehicle shall not be damaged. When the speed is 8 km/hr, the damage of the vehicle shall be limited to the coupler device and carbody buffer device. The load of the abovementioned train is W4.

[2.9.(4).B.b./ 1839092]

When the train collides with the buffer stop of overrun at the speed of 8 km/hr, the coupler device and the carbody buffer device shall not be damaged. When the speed is 16 km/hr, the damage of the vehicle shall be limited to the coupler device and the carbody buffer device. The load of the abovementioned train is W4.

[2.9.(4).C./ 1839093]

*“The anticlimbers shall be set at both ends of every car, in order to avoid the climbing of collided train. In addition, the coupler buffer/energy absorption device shall also be set on every train, in order to absorb the train collision energy to protect the passengers.”*  
According to EN 15227 the SPC can be used as anticlimber and it is foreseen for this project.

[2.15.(1).B.d]

According to the operation requirements, one normal unladen train (S1) shall be capable to push or pull another failed train of the same length and S4 load that stops at any location on the whole line (including the sections with the maximum slope and the minimum turning radius) to the next station, and meet the following requirements:

(a) Service brake and emergency brake of a normal train shall stop these two trains concurrently, and in the event of emergency braking, the emergency brakes on the two trains shall both be actuated.

(b) Under certain special circumstances, the emergency brake of the failed unladen train must be released for movement, which will not be limited by this restriction. But at this time, if it is based on the consideration of system safety, its performance may be reduced where appropriate.

[2.15.(1).B.e]

A normal unladen train (S1) shall be capable to push or pull a failed unladen train to the depot.

[2.15.(1).B.f]

The minimum acceleration of the abovementioned situation is 0.15m/s<sup>2</sup>, and the train speed shall comply with relevant regulations. The Contractor shall submit the relevant analysis and calculation reports of the abovementioned performance requirements and the vehicle rescue and evacuation plan for the Employer's review and approval; and shall conduct actual tests on the track section with the maximum gradient to verify the said performance

## 3.2 System-specific Requirements and Properties

### 3.2.1 Functionality

The ends of a train unit are equipped with automatic front couplings which provide all of the mechanical, pneumatic and electrical connections. They are designed for coupling and uncoupling for towing of defect vehicles. The installed end coupler allows to tow one trainset with another trainset of the same type.

*“The AFC electrical head shall be provided with an heating system to prevent condensation. The heating system shall be regulated by a built-in thermostat or temperature switch aimed to limit the maximum temperature rather than activation on low temperature. The activation of the heating will be realized by contacts on PU scope”.* This shall be offered as an option

The SPC will not have such heating function.

The E-head of AFC should host two potential-free contacts indicating the successful execution of mechanical linkage between vehicles.

The preliminary colour is RAL9005 and will be finally defined in a later stage of the project.

#### Coupler Type of AFC

The coupler head is type 35 preferred from operator side. Depending on the effect on the vehicle performance a type 10 is also possible. The supplier is requested for a corresponding recommendation.

#### Coupling and uncoupling of AFC

Coupling and uncoupling will be controlled from the driver's desk, and the driver acts switch to operate coupling/uncoupling work, it is only permitted in manual driving mode. If necessary, the coupler heads can be separated manually, so the function of manual opening of the electrical and mechanical head is mandatory.

The Trainsets will have an automatic coupling mode with speed control. The coupling speed is adjustable on the driver's Intelligent Display Unit (IDU) in 0,5 km/h steps up to the max. possible coupling speed. Possible maximum coupling speed is depending on the configuration and weight of the trainset and will be determined by an impact calculation at a later stage in the project. Based on customer requirement 2.9.(4).B.a. a preliminary value is 5 km/h.

The mechanical coupler head is also equipped with a manual uncoupling device. The uncoupling device operated by wire is placed at the side of the coupler. Operating staff need to catch the handle of the uncoupling device by standing at side of the cars. Since this has slack, then it can be applied from the side when the operating staff is not anymore between the cars. The force which is necessary to manually decouple the coupler heads should not exceed 250 N.

All in all, the coupling process from the initial mechanical contact of the AFCs to the end of the coupling process (including recognition of new train configuration) should not take more than two minutes. Same for the reverse process of uncoupling.



In case of unintentional train separation, for example caused by mechanical breakage or incorrect activation, the main brake pipe blows out automatically.

Coupling/decoupling must be ensured in the following track layouts:

- Min. curve radius: 50 m / 60 m (workshop / mainline)
- Min s-curves: 75 m – 16.4 m – 100 m and 100 m – 9.7571 m – 100 m

### Centering device

For automatic coupling in the above mentioned tightest track layouts as well as on the entire track a centering device of the AFC is required. Therefore a linkage to the leading bogie need to be foreseen including damper elements not affecting running dynamic behavior. Coupling in s-curves needs to be ensured with guiding the AFC into the right direction depending on the bogie rotation. The centering device will be developed jointly between the SU and PU. The PU will provide the basic data.

In the following Figure 2 the preliminary design space is shown in a schematic illustration:

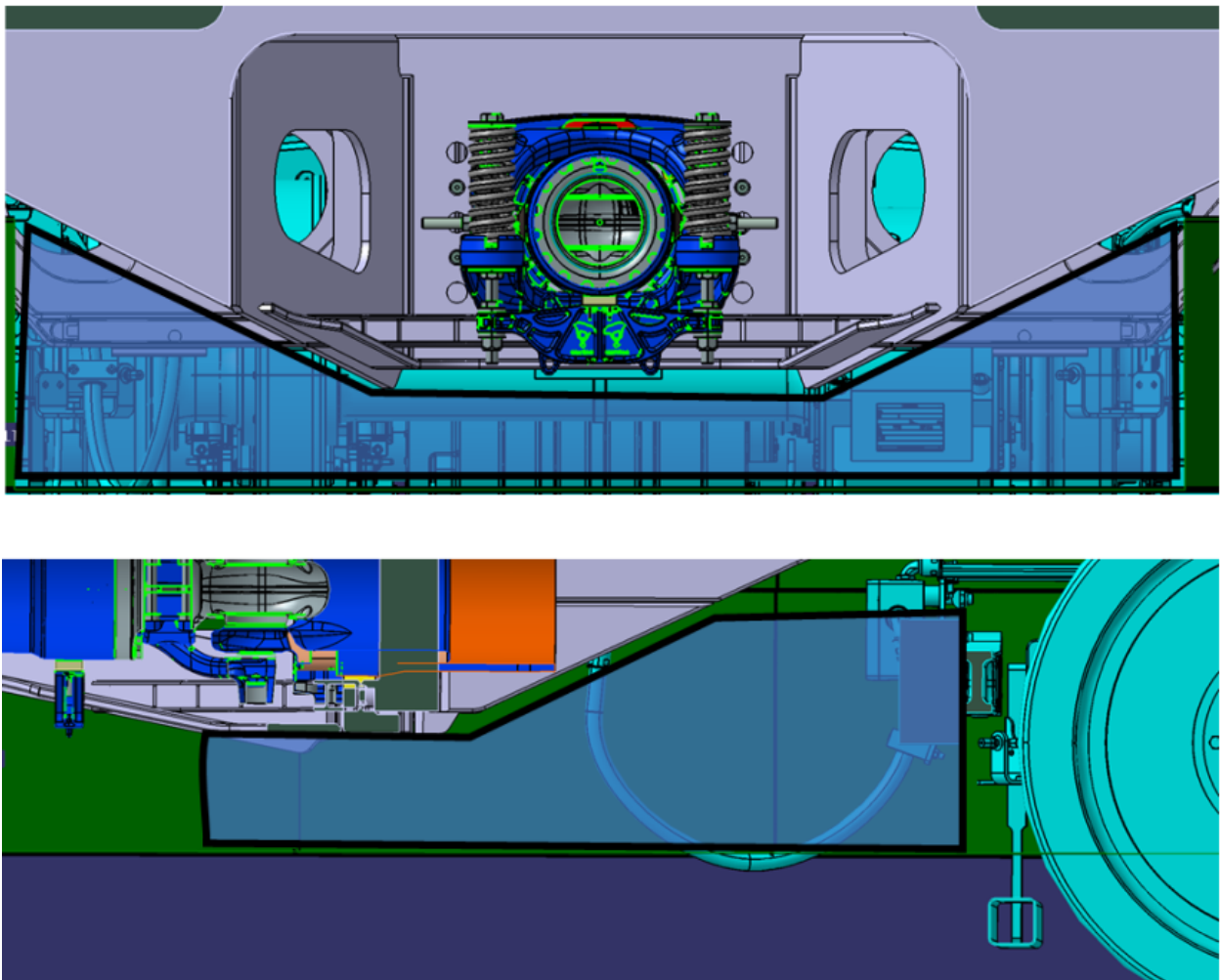

*Figure 2: preliminary design space for centering device (top: front view, bottom: side view)*



### 3.2.2 Mechanical Requirements

#### 3.2.2.1 General Notes for mechanical components

See general technical specification [V1]

#### 3.2.2.2 Weight

See general technical specification [V1]

##### 3.2.2.2.1 AFC

The target weight of the fully equipped including centering device front coupler is 450 kg.

##### 3.2.2.2.2 SPC

The target weight of the fully equipped semi-permanent coupler (both halves combined) is 350 kg.

#### 3.2.2.3 Dimensions and tolerances

For tolerances see general technical specification [V1]

##### 3.2.2.3.1 AFC

The yaw and pitch angles listed in Table 1 are the result of the deflection analysis with the required radius of 50 m for horizontal and 1500 m for vertical curves. The contractor should specify the maximum deflection angles that are possible with the coupler in horizontal and vertical direction.

The dimensions mentioned in Table 1 can change as the crash concept of the unit is not finally defined.

It is highly preferred, that the deformation tube is in front of the mounting surface of the coupler to the car body.

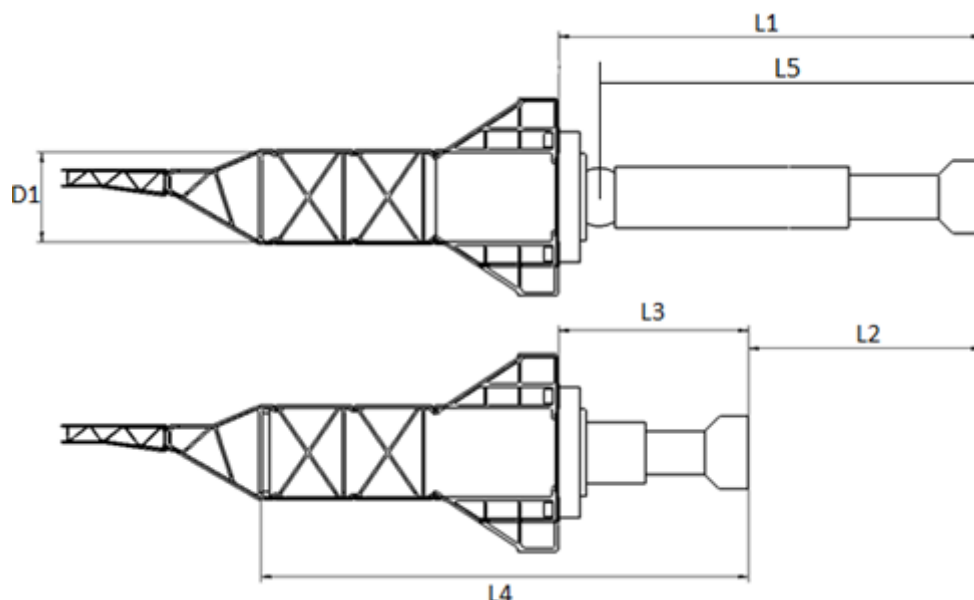

Figure 3: Dimensions of the front coupler

Parameter		Value
Coupler height above top of rail (TOR)		700 mm
Installation length between screw surface (mounting plane) and coupling head (coupler plane)	L1	1765 mm
Total displacement of the coupling head (After activating the predetermined breaking device and including compression of the coupling)	L2	min. 840 mm
Block length between the mounting plane and the coupler plane when fully compressed	L3	max. 925 mm
Maximum allowed total length after compression	L4	max. 1425 mm
Coupler length from the coupler joint to the coupler head	L5	1625 mm
Diameter of the deformation element behind the mounting plane	D1	N/A
Horizontal yaw angle		±20°
Vertical pitch angle		±3,5°

Table 1: preliminary dimensions of the front coupler

### 3.2.2.3.2 SPC

The SPC consists of two halves of the same length. A flange connection keeps the SPC-halves together.

The SPC is equipped with elements for reversible energy absorption. Irreversible energy absorbing elements are currently not foreseen. This might change during the course of the project.

The yaw and pitch angles listed in Table 2 are the result of the deflection analysis with the required radius of 50 m for horizontal and 1500 m for vertical curves. The contractor should specify the maximum deflection angles that are possible with the coupler in horizontal and vertical direction.

The dimensions mentioned in Table 2 can change as the crash concept of the unit is not finally defined.

Parameter	Value
Length between mounting planes	2120 mm
Lengths between pivots and mounting planes	180 mm each
Maximum travel with reversible energy absorption element	100 mm
Maximum travel with irreversible energy absorption element	Not foreseen
Horizontal yaw angle	±30°
Vertical pitch angle	±6°

Table 2: preliminary dimensions of the SPC

### 3.2.2.4 Materials / Chemicals

See general technical specification [V1]

### 3.2.2.5 Strength and energy absorption

Structural category acc. to EN 12663-1: P-|||

Crashworthiness design categories acc. to EN 15227: C-||

#### 3.2.2.5.1 AFC

Function	Evidence
<p><u>Static loads</u></p> <ul style="list-style-type: none"> <li>Tensile force without longitudinal strain: 600 kN</li> <li>Compression force without longitudinal strain: 800 kN</li> </ul>	<ul style="list-style-type: none"> <li>Finite Element Analysis for tension/compression</li> <li>One tension test and one compression test executed by a ISO 17025 certified institute</li> <li>Determination of the force-displacement diagram</li> <li>Application of strain gauges at high stress points</li> </ul>
<p><u>Fatigue loads</u></p>	<ul style="list-style-type: none"> <li>The fatigue strength of the entire coupling is verified as follows:</li> <li>Analytical verification according to the FKM directive and a fatigue test of all structural</li> </ul>

	<p>components, incl. the attachment to the car body</p> <ul style="list-style-type: none"> <li>• Longitudinal load collective: <ul style="list-style-type: none"> <li>○ <math>\pm 400</math> kN, <math>10^3</math> load duty cycles</li> <li>○ <math>\pm 300</math> kN, <math>10^5</math> load duty cycles</li> <li>○ <math>\pm 200</math> kN, <math>2 \times 10^6</math> load duty cycles</li> </ul> </li> <li>• Acceleration forces in X, Y and Z-directions as per EN 12663, <math>10^6</math> load duty cycle</li> <li>• Damage accumulation of the longitudinal and acceleration forces which are mentioned above.</li> </ul>
<p><u>Dynamically reversible</u></p> <p>The energy from a collision of one trainset with</p> <ul style="list-style-type: none"> <li>• a completely rigid, fixed surfaces at a speed of 5 km/h</li> <li>• a buffer stop at a speed of 8 km/h</li> </ul> <p>can be reversibly absorbed.</p> <p>The reversible energy absorption must be gas-hydraulic with a deformation stroke of approx. 150 mm.</p> <p>At the end of the full stroke of the irreversible deformation element, the gas hydraulics must be completely compressed.</p>	<p>A multi-body simulation is performed and submitted in order to design the damper.</p> <p>The PU submits the necessary vehicle data.</p> <p>The preliminary collision mass shall be considered according the weight report AL_6001729 – Chapter 7.3.2.</p>
<p><u>Dynamically irreversible</u></p> <p>The coupler has to provide an irreversible energy absorption function at higher speeds. The deformation element of the coupler has a stroke of min. 190 mm at a force level of approx. 800 kN. The total energy absorption of the coupler has to be at least 255 kJ at 25 km/h.</p>	<p>To verify the energy absorption characteristic of the coupler three dynamic tests with final speeds between 15 and 30 km/h are necessary. EN 15227, Annex B has to be considered. The force level shall be within <math>\pm 10\%</math> of the agreed values. The following data is thereby collected:</p> <ul style="list-style-type: none"> <li>• Force-path curve</li> <li>• Force-time curve</li> <li>• End length</li> </ul>

3.2.2.5.2 SPC

Function	Evidence
<p><u>Static loads</u></p> <ul style="list-style-type: none"> <li>• Tensile force without longitudinal strain: 600 kN</li> <li>• Compression force without longitudinal strain: 800 kN</li> </ul>	<ul style="list-style-type: none"> <li>• Finite Element Analysis for tension/compression</li> <li>• One tension test and one compression test executed by a ISO 17025 certified institute</li> <li>• Determination of the force-displacement diagram</li> <li>• Application of strain gauges at high stress points</li> </ul>
<p><u>Fatigue loads</u></p>	<ul style="list-style-type: none"> <li>• The fatigue strength of the entire coupling is verified as follows:</li> <li>• Analytical verification according to the FKM directive and a fatigue test of all structural components, incl. the attachment to the car body</li> <li>• Longitudinal force load spectrum:               <ul style="list-style-type: none"> <li>○ ±400 kN, 10<sup>3</sup> load duty cycles</li> <li>○ ±300 kN, 10<sup>5</sup> load duty cycles</li> <li>○ ±200 kN, 2x10<sup>6</sup> load duty cycles</li> </ul> </li> <li>• Acceleration forces in X, Y and Z-directions as per EN 12663, 10<sup>6</sup> load duty cycle</li> <li>• Damage accumulation of the longitudinal and acceleration forces which are mentioned above.</li> </ul>
<p><u>Dynamically reversible</u></p> <p>The reversible energy absorption must be gas-hydraulic with a total deformation stroke of approx. 100 mm.</p>	<p>A multi-body simulation is performed and submitted in order to design the damper.</p> <p>The PU submits the necessary vehicle data.</p> <p>The preliminary collision mass shall be considered according the weight report AL_6001729 – Chapter 7.3.2.</p>

<p><u>Dynamically irreversible</u></p> <p>In the current crash concept there is no irreversible stage foreseen. This might change during the course of the project.</p>	

**3.2.2.6 Surface / Corrosion**

See general technical specification [V1]

**3.2.2.7 Identification / Marking / Type Plates / Pictograms**

See general technical specification [V1]

**3.2.2.8 Locking Concept**

See general technical specification [V1]

**3.2.2.9 Installation Instructions**

The front coupler and the SPC halves shall be delivered on a pallet that allows it to be mounted directly onto the car body without any further manipulation. For the design of the pallet the surrounding components (front cabin, rail guard, etc.) have to be considered.

The installation of the AFC and the SPC should be possible without using special tools. If special tools are required, they are in the scope of delivery of the SU.

**3.2.3 Pneumatic Requirements**

**3.2.3.1 AFC**

Function	Evidence
The operating pressure is between 0 and 10 bar.	
The pneumatic hoses are included in the scope of delivery. Datasheets and Specifications of the used plugs has must be indicated. Only Ermeto screw connections with 24° cone shall be used. The length is determined by the PU for the series during the first assembly.	
The pneumatic interface to the carbody-side (pipe connection) for main reservoir pipe	

should be placed at the top of the AFC. And should be guided over the coupler shank.	
Main reservoir pipe: <ul style="list-style-type: none"> <li>• <math>\varnothing 28</math> (Da=28, di=25)</li> </ul>	
For opening of the electrical coupler head during coupling with a defect vehicle a separate pipe shall be foreseen.	
Colour code: <ul style="list-style-type: none"> <li>• Main reservoir pipe: white</li> </ul> This will be finally defined during the course of the project.	
Max. pressure drop	<p>For a coupled pair of AFC max. 0,2 bar within 5 minutes, at a test pressure of 10 bar and a test volume of 10 litres.</p> <p>Alternatively: For a coupled pair of AFC max. 0,5 bar within 10 minutes, at a test pressure of 6 bar and without additional test volume.</p>

### 3.2.3.2 SPC

Not applicable

## 3.2.4 Electrical Requirements

### 3.2.4.1 General Notes for electric components

Compliance with [N4] EN 50155 is required. See also general technical specification [V1] for further information and requirements.

### 3.2.4.2 Energy Supply

#### 3.2.4.2.1 AFC

The heating system shall be supplied by 110Vdc network.

#### 3.2.4.2.2 SPC

Not applicable

### 3.2.4.3 EMC

See general technical specification [V1]

#### **3.2.4.4 Earthing**

##### **3.2.4.4.1 AFC**

Grounding cables shall have a minimum cross-section of 50 mm<sup>2</sup> between coupler head, draft gear, and car body. A reduced cross-section of 35 mm<sup>2</sup> can be used between mechanical coupler head and electrical coupler head. If the design of E-head is made with two separated units, a 16 mm<sup>2</sup> cable can be used on each of them.

##### **3.2.4.4.2 SPC**

The SPC shall be grounded with a cable of a minimum cross-section of 50 mm<sup>2</sup> and equipped with a grounding stud (M10) for the Gangway's grounding cable.

#### **3.2.4.5 Power Consumption**

It is expected a power consumption of the heating element(s) as per chapter 3.2.4.2.1 in the range 50-100 W. Stadler rely on SU expertise for exact dimensioning of such elements, in accordance with specific Kaohsiung climatic conditions (see. [V1]). The final value shall be agreed between SU and PU.

#### **3.2.4.6 Cabling and Electrical Connections**

##### **3.2.4.6.1 AFC**

Harting type plugs shall be used to connect the vehicle to AFC and included in the scope of delivery.

In the first delivery batch the cables are delivered with an extra length (3 m) and loose plugs. The plugs are fitted by the PU during initial assembly, thus to determine the definitive cable length, which is then communicated to SU for the series production.

Cable supports shall be provided and included within the 3D for Stadler for evaluation. Number and position of such supports will be reviewed and agreed between SU and PU up to a finalized solution.

A single, rugged, multi-conductor wire harness shall extend from the back of the electric head(s) through a bulkhead strain relief fitting, with enough length and flexibility to allow for all coupler motion and connection to the vehicle.

The following signals are to be transmitted via the E-head, these data are highly preliminary and will be updated during the course of the project (referenced document number will be submitted later):



Front-Automatic-Coupler (FAC)																			
Signal Name	Spare	Richtig im Schema mit Seitenangabe	cross section / current	Cable construction	Opens when the decoupling button is pressed	Opens when the coupler is disconnected	Connector	AFC			Vehicle								
								E-Head bush	E-Head pin	Cross-connected	Size	Module	PIN	Harding Module					
Megabit TCMS KS			Cat5e	4x22AWG, screened			X02	x			HAN Z4B	A	1	Han MEGABIT 10105946 12120149					
Megabit PIS KS			Cat5e	4x22AWG, screened				x					2	Han MEGABIT 10105946 12120149					
Vehicle activation (TF-GA1) Train occupied +			1,5mm <sup>2</sup>	Single core		x							HAN Z4B	B	1	Han DD			
Vehicle activation (TF-GA1) Train occupied -			1,5mm <sup>2</sup>	Single core		x									2				
Brake Status COP_X6 All Brake Applied Train			1,5mm <sup>2</sup>	Single core		x									3				
Brake Status COP_X6 All Brake Released Train			1,5mm <sup>2</sup>	Single core		x									6				
Brake Status COP_X6 NO Brake Isolated train			1,5mm <sup>2</sup>	Single core		x									7				
Power Supply for Trains (COP-GA1) +			1,5mm <sup>2</sup>	Single core		x									8				
Power Supply for Trains (COP-GA1) -			1,5mm <sup>2</sup>	Single core		x									9				
No Passenger alarm			1,5mm <sup>2</sup>	Single core		x									10				
EB Loop + COP_X13			1,5mm <sup>2</sup>	Single core		x									11				
EB Loop + COP_X13 Valves			1,5mm <sup>2</sup>	Single core		x									12				
Traction Safe (SF-JA1) +			1,5mm <sup>2</sup>	Single core		x						1			HAN Z4B		C	1	Han DD
Traction Safe (SF-JA1) -			1,5mm <sup>2</sup>	Single core		x						2							
Doors safety loop left +			1,5mm <sup>2</sup>	Single core		x						3							
Doors safety loop left - return			1,5mm <sup>2</sup>	Single core		x						4							
Doors safety loop right +			1,5mm <sup>2</sup>	Single core		x						5							
Doors safety loop right - return			1,5mm <sup>2</sup>	Single core		x						6							
Doors release left			1,5mm <sup>2</sup>	Single core		x						7							
Doors release right			1,5mm <sup>2</sup>	Single core		x						8							
Doors close			1,5mm <sup>2</sup>	Single core		x						9							
No Emergency door handle (No evacuation request)			1,5mm <sup>2</sup>	Single core		x						10							
No Fire Alarm (full CBTC)			1,5mm <sup>2</sup>	Single core		x						11							
Spare 1	x		1,5mm <sup>2</sup>	Single core								12							
empty											D	1	Dummy 12015211						
DC Backbone + KS			35mm <sup>2</sup> because of filling factor / 80A	Single core		x		x			E	1	Han 100A Crimp Module 12099389, 12100512						
DC Backbone - KS			35mm <sup>2</sup> because of filling factor / 80A	Single core		x		x			F	1	Han 100A Crimp Module 12099389, 12100512						
Megabit TCMS TS			Cat5e	4x22AWG, screened			X04		x		HAN Z4B	A	1	Han MEGABIT 10105946 12120149					
Megabit PIS TS			Cat5e	4x22AWG, screened					x					2	Han MEGABIT 10105946 12120149				
Coupler Status (TF-SA1) +			1,5mm <sup>2</sup>	Single core		x			x				HAN Z4B	B	1	Han DD			
Coupler Status (TF-SA1) -			1,5mm <sup>2</sup>	Single core		x				x					2				
Spare 2	x		1,5mm <sup>2</sup>	Single core		x									3				
Spare 3	x		1,5mm <sup>2</sup>	Single core		x									6				
Spare 4	x		1,5mm <sup>2</sup>	Single core		x									7				
Spare 5	x		1,5mm <sup>2</sup>	Single core		x									8				
Spare 6	x		1,5mm <sup>2</sup>	Single core		x									9				
Spare 7	x		1,5mm <sup>2</sup>	Single core		x									10				
Spare 8	x		1,5mm <sup>2</sup>	Single core		x									11				
Spare 9	x		1,5mm <sup>2</sup>	Single core		x									12				
Train Integrity Trainline 1/4 (+)			1,5mm <sup>2</sup>	Single core		x						HAN Z4B			C		1	Han DD	
Train Integrity Trainline 2/4 (+)			1,5mm <sup>2</sup>	Single core		x											2		
Train Integrity Trainline 3/4 (-)			1,5mm <sup>2</sup>	Single core		x							3						
Train Integrity Trainline 4/4 (-)			1,5mm <sup>2</sup>	Single core		x							4						
EB Loop - COP_X13 Valves			1,5mm <sup>2</sup>	Single core		x							5						
EB Loop - COP_X13			1,5mm <sup>2</sup>	Single core		x							6						
Spare 10	x		1,5mm <sup>2</sup>	Single core									7						
Spare 8	x		1,5mm <sup>2</sup>	Single core									8						
Spare 9	x		1,5mm <sup>2</sup>	Single core									9						
Spare 10	x		1,5mm <sup>2</sup>	Single core									10						
Spare 11	x		1,5mm <sup>2</sup>	Single core									11						
Spare 12	x		1,5mm <sup>2</sup>	Single core									12						
empty											D	1	Dummy 12015211						
DC Backbone + TS			35mm <sup>2</sup> because of filling factor / 80A	Single core		x			x		E	1	Han 100A Crimp Module 12099389, 12100512						
DC Backbone - TS			35mm <sup>2</sup> because of filling factor / 80A	Single core		x			x		F	1	Han 100A Crimp Module 12099389, 12100512						

Table 3: preliminary AFC signals

### 3.2.4.6.2 SPC

The SPC scope of delivery shall include supporting elements for the jumper. The jumpers itself will be on PU scope. The exact implementation of the supporting elements will be agreed between SU and PU in a later stage of the project.

**3.2.4.7 Communication interface**

Not applicable

**3.2.5 Software Requirements**

Not applicable

**3.2.6 Diagnosis and Failure Behaviour**

See general technical specification [V1]

**4 Interfaces**

**4.1 Mechanical Interfaces**

**4.1.1 AFC**

The AFC is mounted to the car body with 4 M30 screws, using the following Interface:

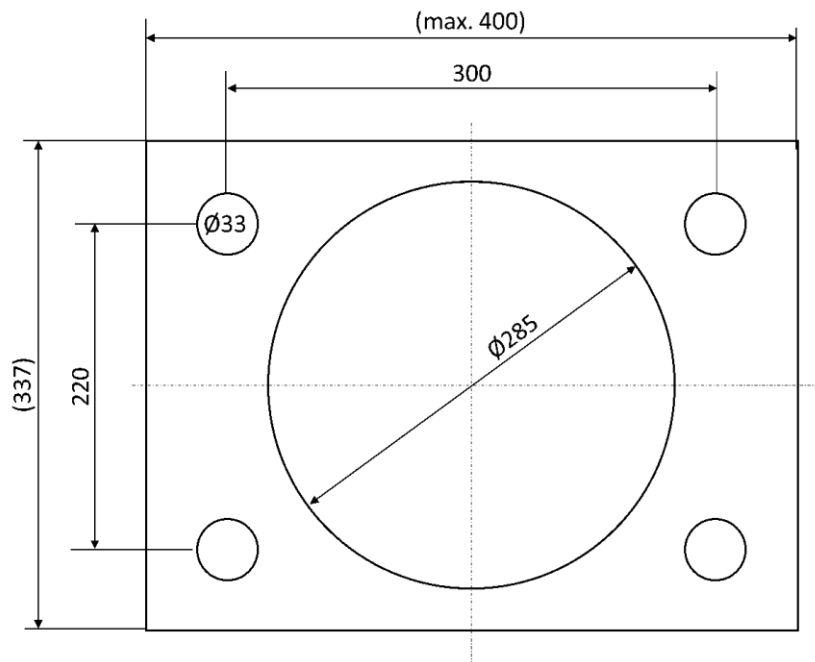

Figure 4: preliminary Mechanical Interface AFC

**4.1.2 SPC**

The SPC is mounted to the car body with 4 M30 screws, using the following Interface:

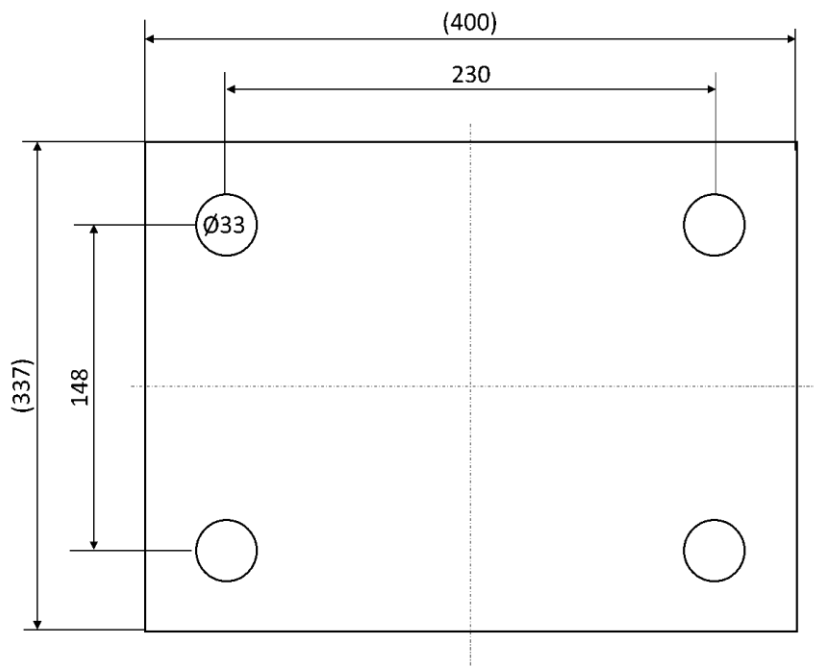

Figure 5: preliminary Mechanical Interface SPC

There is also a support plate for the gangway at the top in the middle between two cars necessary. Details of this interface will be agreed between the SU and the PU during the project.

## 4.2 Pneumatic Interfaces

Refer to chapter 3.2.3.

## 4.3 Electrical Interfaces

Refer to chapter 3.2.4.

## 4.4 Software Interfaces

Not applicable

# 5 RAM/LCC, Special Tools, Spare Parts and Maintenance Requirements

See general technical specification [V1] and general RAM specification [V2].

## 5.1 Risk analysis

See general technical specification [V1]

## 5.2 Requirement management

See general technical specification [V1]

### **5.3 Development Process**

See general technical specification [V1]

### **5.4 Verification and validation**

See general technical specification [V1]

### **5.5 System integration**

See general technical specification [V1]

### **5.6 Lifecycle management**

See general technical specification [V1]

### **5.7 Documentation**

See general technical specification [V1] and also the requirements stated in chapter 8.

### **5.8 Reliability**

See general technical specification [V1]

### **5.9 Availability**

See general technical specification [V1]

### **5.10 Life Cycle Cost (LCC)**

See general technical specification [V1]

### **5.11 Maintainability**

See general technical specification [V1] and general RAM specification [V2].

### **5.12 Accessibility**

See general technical specification [V1]

### **5.13 Spare Parts**

See general technical specification [V1]

The contractor must guarantee the availability of spare parts for 30 years. Assemblies / systems that are no longer available over this period must be able to be replaced by substitute products with the same electrical, pneumatic and mechanical interfaces. The contractor need to supply a spare parts list.

## 5.14 Special Tools

See general technical specification [V1]

## 5.15 Maintenance Justification

See general RAM specification [V2]

# 6 Safety

See general technical specification [V1]

The supplier of components and subsystems is also responsible for the health and safety of passengers, operators and other parties. Therefore, the SU has to assure to develop and provide products that are safe for their intended use.

The supplier is responsible for the safety of his product or the subsystem in operational environment.

The system safety is achievable only if all suppliers perform their part of the safety process in a correct manner according to the requirements.

The components and subsystem has to be designed according to the state of the art by standards, guidelines and rules of technology.

The supplier must carry out a hazard analysis in accordance to EN 50126 to demonstrate the safety of its product.

# 7 Tests and Acceptances

See general technical specification [V1]

All contractually warranted characteristics of the contractual product that are required for its intended use and its fulfilment of the applicable statutory and official regulations as well as the relevant norms and standards must be verified by suitable tests.

Existing proofs shall be accepted and should be submitted to the PU for approval.

## 7.1 Inspections and Test Schedule

See general technical specification [V1]

## 7.2 Test Certificates and Test Schedule

See general technical specification [V1]

## 7.3 Pre FAI

See general technical specification [V1]

## **7.4 First Article Inspection**

An FAI is mandatory for all specified components.

See general technical specification [V1]

## **7.5 Type Test**

See general technical specification [V1]

Refer to chapter 3.2.2.5 for mechanical tests.

Refer to chapter 3.2.3.1 for pneumatic tests.

## **7.6 Series Test**

See general technical specification [V1]

## **7.7 Acceptance**

See general technical specification [V1]

The SU has to create a Validation Plan for each relevant subcomponent of the coupling system. For identical parts of the coupling system, which have already been validated in other projects with the same or stronger requirements, the SU is allowed to show a declaration of conformity.

# **8 Documentation**

See general technical specification [V1] and request of quotation.

## **8.1 User Documentation**

See request of quotation

## **8.2 Engineering Documentation**

See request of quotation

### **8.2.1 Installation instructions**

See request of quotation

## **8.3 Configuration Management**

See general technical specification [V1]

# **9 Training and Support**

See general technical specification [V1]

## 10 Scope of Delivery

### 10.1 Scope of delivery - Quotation Phase

The scope of delivery is described in this table, yet it is unconfined. A final alignment between parties before distribution is obligatory.

Position	Description	After inquiry
<b>Technical offer:</b>		
1	Clause-by-clause (GTS + Specification + Requirements)	<b>4 weeks</b>
2	Delivery and admission schedule (earliest possible delivery, lead time, road-map, Test Schedules, Training program/concept, etc.)	<b>4 weeks</b>
3	Description of the proposed system(s)	<b>4 weeks</b>
4	Concept 3D (2D as reference form previous projects if available)	<b>4 weeks</b>
5	Data sheets and description of the components (if available)	<b>4 weeks</b>
<b>Commercial offer:</b>		
6	Pricing overall system	<b>4 weeks</b>
7	Pricing of any applicable options	<b>4 weeks</b>
8	RAMS/LCC data	<b>4 weeks</b>

Table 4: Scope of delivery for quotation phase

### 10.2 Scope of Supply

The scope of supply is described in this table, yet it is unconfined. A final alignment between parties before delivery is obligatory.

Position	Description	After order
<b>Hardware and Supplies:</b>		
1	Automatic Front Coupler	<b>50 pcs</b>
2	Semi-permanent Coupler	<b>50 pcs</b>
3		
<b>All Engineering Documentation, User Documentation, Certificates and relevant evidence material and documentation referred on the FTP Server</b>		

Table 5: Scope of Supply