

Document No. **BU_6066978**

Index **_**

Status Released

Document type Specification

Number of pages 15

Drawgears and pushers

P-77694 Enterprise

Created (first version)		Checked (current index)		Released (current index)	
Name	Date	Name	Date	Name	Date
gerpir	21.08.2024	becchr	27.08.2024	schrol	27.08.2024

This document may not be copied or made accessible to unauthorized persons without our permission, nor may the parts shown on it be reproduced.

List of changes

Index	Amendment	Date	Created	Tested	Released
–	First version	21.08.2024	P. Gerspacher	C. Beck	C. Beck
a					
b					
c					

Contents

1 Introduction.....	4
1.1 General information	4
1.2 Validity of the specification.....	4
1.3 System responsibility	4
1.4 Abbreviations	4
1.5 Applicable specifications.....	4
1.6 Other applicable documents and annexes	4
1.7 Contract language.....	4
1.8 Confidentiality	4
1.9 Vehicle composition	5
1.10 Operating cycles and service life of the vehicle.....	5
1.11 Specific information on the vehicles	5
1.12 Operating cycles and service life of the vehicle.....	5
2 Standards and regulations	5
3 Technical requirements and properties	6
3.1 General requirements	6
3.1.1 Specific requirements of the customer	6
3.1.2 Sound requirements and vibration.....	7
3.1.3 Authorization	7
3.1.4 Climatic requirements	7
3.1.5 Fire protection	7
3.1.6 Welded assemblies	7
3.1.6.1 <i>Notes on mechanical components</i>	7
3.1.7 Serviceability and maintenance	7
3.1.8 Ecology / environmental requirements	7
3.1.9 Tolerances	7
3.1.10 Quantity structure.....	8
3.1.11 Surface / Corrosion	8
3.1.12 Fittings	8
3.2 Front coupling	8
3.2.1 Functionality.....	8
3.2.2 Electrical requirements	9
3.2.2.1 <i>Electric clutch</i>	9
3.2.2.2 <i>Earthing system</i>	9

3.2.3	Mechanical requirements.....	9
3.2.3.1	<i>Dimensions</i>	9
3.2.3.2	<i>Mechanical interfaces</i>	10
3.2.3.3	<i>Strength and energy absorption</i>	10
3.2.3.4	<i>Weight</i>	11
3.2.4	Pneumatic requirements	12
3.3	Draw hooks - Type 10 adaptor couplers	12
3.3.1	Functionality of towing hook - Type 10 adaptor coupler	12
3.3.2	Mechanical requirements.....	13
3.3.2.1	<i>Strength</i>	13
3.3.2.2	<i>Weight</i>	13
3.3.3	Pneumatic requirements	13
4	RAMS / LCC	13
5	Tests and approvals	13
5.1	Approval.....	13
5.2	Tests and test plan	14
5.3	Test certificates and test documentation	14
5.4	First Article Inspection	14
5.5	Type test	14
5.6	Series test.....	14
6	Documentation	14
6.1	Configuration management.....	14
6.2	User documentation	14
6.3	Technical vehicle documentation	14
7	Training and support	14
8	Scope of delivery	15

1 Introduction

1.1 General information

The vehicle corresponds approximately to the "FLIRT^{UK}" platform and is a multi-part single-deck electric multiple-unit train with a fixed design. A train set consists of pairs of cars connected via intermediate couplings.

See type sketch 131694 TriMU10 [V3]

1.2 Validity of the specification

This TS is valid for the same duration as the general technical specification [V1].

1.3 System responsibility

See general technical specification. [V1]

1.4 Abbreviations

AG	Client
CONTRACTOR	Contractor
	HLMain line (brake line)
MRP	Main tank line (feed line)
	LCCLife Cycle Cost
RAMSReliability	, Availability, Maintainability, Safety
SOK	Top edge of rail
	TSTechnical specification

1.5 Applicable specifications

This TS is to be understood as a supplement to the general technical specification BU_XXXXXX [V1].

1.6 Applicable documents and annexes

- [V1] BU_XXXXXX General technical specification (tbd) [V2]
521085 FLIRT UK Vehicle deflection
- [V3] 131694 TriMU10
- [V4] EastAnglia_Kupplungsauslegung_V1
- [V5] BU_YYYYYYY Color list (tbd)

1.7 Contract language

See general technical specification. [V1]

1.8 Confidentiality

See general technical specification. [V1]

1.9 Vehicle composition

See general technical specification. [V1]

1.10 Operating cycles and service life of the vehicle

See general technical specification. [V1]

1.11 Specific information on the vehicles

See general technical specification. [V1]

1.12 Operating cycles and service life of the vehicle

See general technical specification. [V1]

2 Standards and regulations

See general technical specification. [V1]

The following standards and regulations must be explicitly observed:

[N1]	2002/95/EC	Directive on the restriction of the use of certain hazardous substances in electrical and electronic equipment
[N2]	DIN 25201	Design guideline for rail vehicles and their components - Bolted joints
[N3]	EN 12663	Strength requirements for rail vehicle bodies
[N4]	EN 15085	Welding of rail vehicles and vehicle parts
[N5]	EN 17025	General requirements for the competence of testing and calibration laboratories
[N6]	EN 45545	Fire protection in rail vehicles
[N7]	EN 50121	Electromagnetic compatibility
[N8]	EN 50125	Environmental conditions for equipment
[N9]	EN 50126	Specification and verification of reliability, availability, maintainability, safety (RAMS)
[N10]	EN 50155	Electronic equipment on rail vehicles
[N11]	EN 60950	Information technology equipment - Security
[N12]	UIC 345	Environmental specifications for rail vehicles
[N13]	VDI 2230	Systematic calculation of highly stressed screw connections
[N14]	ISO 8015	Geometrical product specifications
[N15]	ISO 2768	General tolerances
[N16]	GM/GN2690	RGS guidance appendix 7 for both mainline and non-passenger lines.

3 Technical requirements and properties

3.1 General requirements

3.1.1 Specific requirements of the customer

Req. ID	Requirement
ID-0895	Dead haulage recovery shall be automatic and be capable within a time of 10 minutes.
ID-0181	The Trains shall be capable of being rescued in class and by a Class 201 Locomotive in both Electrically Live and Electrically Dead states to allow through Braking functionality throughout both Loco and Train. This is expected to take no longer than 10 minutes, from the point of coupling to the point of being ready to move and shall minimize the activities required by the operator to complete. The design and process shall be agreed at Design Review.
ID-0931	The trains shall be able to navigate all curves on the specified routes for all design speeds. Rolling stock must be capable of the following: <ol style="list-style-type: none"> Safely negotiating curves of radius 110 m in the running line. Safely negotiating curves of radius 80 m in sidings. Running through a curve of radius 120 m, reversing to a curve of radius 120 m separated by 2 m of straight track.
ID-0896	If all necessary safety systems remain functional on a failed Train, it shall be possible to haul that Train in passenger service at speeds of up to 100km/h for a minimum of 60 minutes.
ID-0898	Coupler systems with retractable 'nose cone' covers should ensure that trains can only be coupled once the covers have been opened. Note, couplers should not be retractable.
ID-0359	The Supplier will identify limitations of the couplers using the TIIS and any areas where this may not be possible, for example coupling on curves etc. To be agreed at Design Review.
ID-0901	Individual vehicles and any combination of vehicles within a Train shall be capable of being coupled and decoupled without the need for specialist tools, other than support devices enabling articulated vehicles (if proposed) to be separated. The Supplier is to propose methods for, and any constraints on, how such individual and combinations of vehicles can be split (including consideration of gangways), moved and lifted for maintenance, overhaul and repair. Note: this requirement ID-0901 relates to the separation of individual vehicles or combinations of vehicles in smaller elements than the 'half-Train' sections referred to in ID-0900.
ID-0900	Trains shall be capable of being split both automatically and manually as near to the longitudinal center point of the Train as the Train architecture allows. The splitting and subsequent recoupling activities (including splitting/joining of gangways and jumper cables but excluding testing after recoupling) shall each be achieved in no longer than 5 minutes. <i>When split in this way, it is desirable that each of the two sections shall be able to propel itself in both directions. Where the traction architecture precludes this functionality, the Supplier is to propose how the split sections of a Train shall be moved around the Home Depot to ensure all maintenance tasks can be conducted efficiently.</i>
ID-0913	The total time for automatic mechanical & pneumatic coupling and uncoupling between trains shall take no more than 5 minutes to perform.
ID-0915	The control of coupling and uncoupling shall be possible from the driving cab.

ID-0916	The trains shall have a means of manually uncoupling in the event of failure of the automatic system.
ID-0914	The couplers shall have mechanical and pneumatic functionality for rescue purposes. Rescue must be capable with IÉ/Translink Class 201 Diesel Locomotive.
ID-0911	The coupler shall be protected from impact with items placed on the railway track and protected from build-up of ice, snow and dirt, as well as bird strikes. Protection should not lead to a build-up of moisture within the coupler or coupler connections.
ID-0163	The train shall have automatic couplers for mechanical and pneumatic connections at both cab ends. Electrical connections when coupling at the cab ends shall be achieved manually using railway approved jumpers and receptacles. It shall not be possible to connect the electrical connections incorrectly.

3.1.2 Sound requirements and vibration

The coupler must withstand the stresses caused by vibration and shock for attachments in accordance with EN 12663.

EN 61373 applies to oscillation and shocks.

3.1.3 Authorization

3.1.4 Climatic requirements

See general technical specification. [V1]

3.1.5 Fire protection

See general technical specification. [V1]

3.1.6 Welded assemblies

See general technical specification. [V1]

3.1.6.1 Notes on mechanical components See

general technical specification. [V1]

3.1.7 Serviceability and maintenance

See general technical specification. [V1]

3.1.8 Ecology / environmental requirements

See general technical specification. [V1]

3.1.9 Tolerances

according to ISO 8015 [V1] and general tolerances according to DIN ISO 2768-mK [V1]

3.1.10 Quantity structure

A train set consists of 10 individual cars.

The two end cars are equipped with automatic front couplers. The set includes 8 sets with 2 front couplers each.

15 - 20 vehicles are planned as options

3.1.11 Surface / Corrosion

The pre-treatment and coating of the coupling components must always ensure permanent and reliable corrosion protection. The contractor proposes a coating structure that must be approved by the client.

The color for the coupler is RAL 9005 [V5].

3.1.12 Fittings

The bolted joints are designed in accordance with DIN25201. The screw connections are verified in accordance with VDI2230.

3.2 Front clutch

3.2.1 Functionality

The ends of a multiple unit are equipped with automatic front couplers, which establish all mechanical and pneumatic connections. They are designed for coupling and uncoupling under operating conditions.

The front coupler is mechanically compatible with coupler head type 10.

The front coupling is designed to minimize the occurrence and transmission of vibrations to the vehicle body during driving. This applies both in the uncoupled and coupled state. In addition to the natural vibrations in the vertical and lateral directions, the longitudinal dynamics in the train set are also optimized with regard to ride comfort.

The coupling travel is semi-automatic or fully automatic. The coupling speed is 0.5 to 5 km/h. The contractor calculates the curve radius up to which automatic coupling is possible. The client provides the necessary vehicle data.

The coupler heads can be separated manually if required. A corresponding release device is provided on the coupler.

In the event of unintentional train disconnections, e.g. due to mechanical breakage or faulty control, the main line blows out automatically.

3.2.2 Electrical requirements

3.2.2.1 Electric clutch

An electric clutch is not required.

3.2.2.2 earthing system

An earthing connection is provided on the coupling side. The cable cross-sections are 50mm². The earthing cable between the coupler head and the electric head must have a cross-section of 2x 6mm².

3.2.3 Mechanical requirements

3.2.3.1 Dimensions

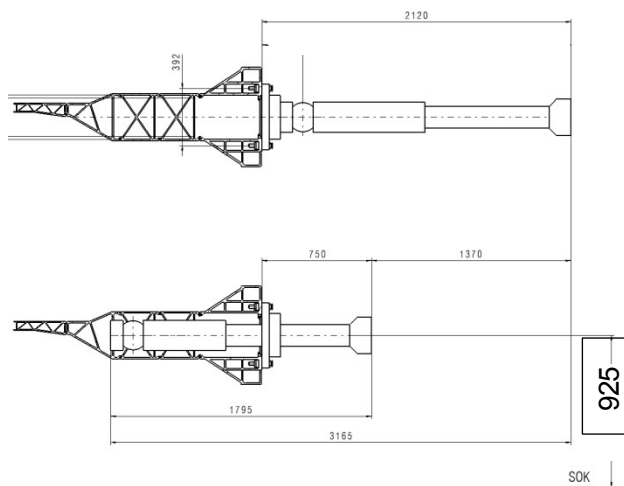

- Length from mounting level to coupling level: 2120 mm
- Maximum remaining length after compression: 1795 mm
- Displacement of the coupler head: 1370 mm
- Block length fully compressed: 750 mm

The joints enable cardanic movements with the following deflections:

See "521085 FLIRT UK vehicle deflection". [V1]

- Horizontal swivel angle: $\pm 16^\circ$
- Vertical pitch angle: $\pm 5^\circ$

3.2.3.2 Mechanical interfaces

Fastening to the vehicle body is carried out according to the following hole pattern using 8 pcs. M24 screws. Fasteners are included in the scope of delivery.

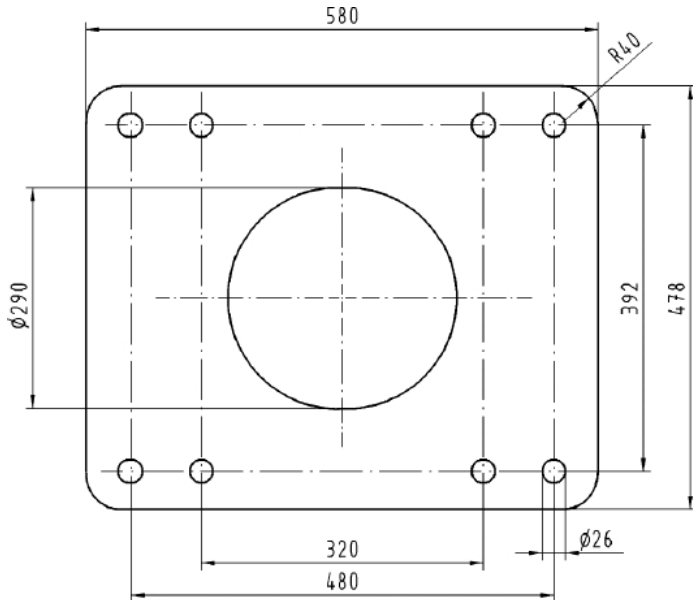

3.2.3.3 Strength and energy absorption

Static

Tensile force without plastic strains: 1000 kN

Compressive force without plastic strains: 1500 kN

- The static strength is verified as follows:
- FEM calculation for tension/compression
- One tensile and one compression test
- Determining the force-displacement curve
- Application of strain gauges in highly stressed areas

Dynamically reversible

The energy of an impact on a trainset configuration at the same standstill is reversibly absorbed up to a speed of 5 km/h. A gas-hydraulic damper with a minimum stroke of 100 mm is used for this purpose.

A multi-body simulation is carried out and submitted for the design of the damper. The contractor provides the necessary vehicle data. The result of the multi-body simulation is verified by the following tests with the complete coupling:

- 3 dynamic tests against an identical coupler
- Run-up speed between 5 and 8 km/h
- At least 80% of the energy consumption must be utilized.

The final operating force is 1500 kN.

Dynamically irreversible

An irreversible energy absorption function must be provided for collisions at higher speeds. This fulfills the following requirements as outlined in [V4] EastAnglia_Kupplungsauslegung_V1.

At the end of the complete lifting movement of the deformation element on the bearing bracket, the gas hydraulics must also be fully retracted. It may be necessary to further increase the force level at the end of the lifting movement in order to initiate the deformation process at the counter clutch.

The following evidence is required:

- 3 dynamic tests with final speeds between 20 and 40 km/h, of which
- 1 Test at room temperature without height offset
- 1 test at -20°C without height offset
- 1 test at room temperature with a height offset of 40 mm against an identical coupler

The following data is determined:

- Force-displacement curve
- Force-time curve
- Final length

If irreversible energy absorption is activated (crash loads > 1500 kN), the coupler head may be plastically deformed. The same applies to the bearing bracket, whereby the penetration of the coupler shank must not be impeded.

Activation must be clearly indicated for operational purposes and be easy to determine. A resonance test is not sufficient.

Fatigue

The fatigue strength of the entire coupler is verified as follows:

- Calculatory verification according to FKM guideline and vibration test of all structural components incl. attachment to the car body
- Load spectrum longitudinal forces: ± 400 kN, 10^3 load changes
 ± 300 kN, 10^5 Load change
 ± 200 kN, $2 \cdot 10^6$ Load change
- Acceleration forces in the X, Y and Z directions in accordance with EN 12663, 10^6 load changes
- Accumulation of damage from the above longitudinal and acceleration forces

3.2.3.4 Weight

The target weight is 650 kg per coupler.

3.2.4 Pneumatic requirements

The pneumatic hoses are supplied. They are marked red (BP) or blue (MRP) at their ends. Only Ermeto fittings with a 24° cone are used. The length of the hoses is determined during the first assembly for the series.

The operating pressure is between 0 and 10 bar. For a coupled pair of front couplings, the maximum pressure loss per line is 0.2 bar within 5 minutes, at a test pressure of 10 bar and a test volume of 10 l.

The pneumatic clutch for unlocking the counter clutch must be present.

3.3 Draw hooks - Type 10 adaptor couplers

3.3.1 Functionality of towing hook - Type 10 adaptor coupler

Adaptor couplers for mechanical and pneumatic coupling of the front coupler to a locomotive with a UIC drawhook are positioned at strategically favorable points in the route network. The number can be found in chapter 0.

The adaptor coupler can be fitted by 2 people within 5 minutes (time without provision).

3.3.2 Mechanical requirements

3.3.2.1 Strength

Tensile force without plastic strain: 300 kN Compressive

force without plastic strain: 250 kN

The static strength is verified by means of an FEM calculation.

3.3.2.2 Weight

The adaptor couplers should consist of as few parts as possible. Each part must not weigh more than 25 kg.

3.3.3 Pneumatic requirements

The air pipes (BP and MRP) are connected manually via the transition coupling. The pneumatic hoses are supplied. The length is to be determined by the contractor. They are marked red (BP) or blue (MRP) at their ends. The types of pneumatic connections to the towing vehicle will be defined later in the project.

The operating pressure is between 0 and 10 bar.

4 RAMS / LCC

See general technical specification. [V1]

5 Tests and approvals

5.1 Authorization

The client decides on a case-by-case basis which topics the client will allow and which, if any, the contractor will allow. Irrespective of this, the contractor is responsible for the eligibility of its components. The expert opinions commissioned directly by the client are the property of the client and are not available to the contractor. The Contractor shall prepare a verification plan for all required verifications and coordinate this with the Client after the order has been placed.

All relevant evidence and test certificates for compliance with the applicable national regulations and standards as well as the requirements of this specification must be enclosed for approval by the client.

It can and should be based on already performed computational and experimental verifications.

Tests must be carried out at a testing institute certified in accordance with EN 17025. Failed tests must be repeated at the Contractor's expense. Dynamic tests must be documented accordingly (incl. high-speed camera, recording rate for forces and deformations 2000 Hz). The measurement signals are filtered with a 180 Hz low-pass filter to document the measurement results.

5.2 Tests and test plan

The Contractor shall prepare a test plan for series and type testing. This must be submitted to the client for approval.

5.3 Test certificates and test documentation

All tests are documented by the contractor. The type of documentation is defined in the test planning. The force-displacement characteristics must be made available in electronic form.

5.4 First Article Inspection

An initial sample inspection must be carried out at the contractor's premises. The date of the initial sample inspection must be agreed at least 18 days in advance. The calendar week is to be proposed with the order confirmation.

5.5 Type test

The Contractor shall participate in the type test of the vehicle insofar as its component is affected. For this purpose, the Contractor shall provide appropriate specialists who have sufficient knowledge and authorization to make any necessary changes and/or adjustments to the component.

5.6 Series test

Serial tests are carried out by the contractor at the contractor's premises in accordance with the test plan. The performance of the tests is confirmed in the test certificate.

6 Documentation

6.1 Configuration management

See general technical specification. [V1]

6.2 User documentation

See general technical specification. [V1]

6.3 Technical vehicle documentation

See general technical specification. [V1]

7 Training and support

See general technical specification. [V1]

8 Scope of delivery

Position	Upon receipt of request	After receipt of order	Delivery date according to project schedule
16 front coupler type 10 without heating and electric head (EMU)			X
8 pieces Drawhook part transition coupler type 10 - UIC drawhook			X
Description of the components	X		
Delivery times	X		
Spare parts list (incl. costs of individual parts and delivery time)		X	
Installation guidelines for all components		X	
Operating manuals		X	
Mechanical drawing set		X	
3D data	X		
Certificates (incl. QS certificates)		X	
Test protocols		X	
Strength verification of the components		X	
Complete parts list		X	