

## Quotation

To

Company :	Siemens AG	Name :	N. HOST
City / Country :	Duisburg / Germany	Dept :	Sales Dept.
Name :	Stoverink Simon	Tel :	+33 (0)3 69 20 51 50
Dept :		Fax :	+33 (0)3 88 67 60 75
Tel :		E-mail :	nhost@flender-graff.com
Fax :		Page(s) :	19
E-mail :		Copy :	
		Date :	16.03.2015

Y/ref : Khursaniyah Al Fadhili - D43-K-1801 -  
O/ref : D41104 quotation number 3

In response to your inquiry referenced above, we are pleased to confirm our quotation as follows :

### ITEM A 1 : Flender Graffenstaden (FG) High Speed increaser, model **TX50/4C**

- *Rating conditions :* Rated power at **6800 kW**  
Driven by a electric motor at **1800.0 rpm** (specified : 1800.0 rpm)  
Driving a centrifugal compressor at **7309.1 rpm** (specified : 7285.0 rpm)  
Service factor **1.45** according to **API613/03** (required : > 1.4)
  
- *Technical description :* Double helical  
Manufacturing according to API standard  
Flange on LS shaft end  
Flange on HS shaft end  
Estimated Weight : 4000 kg
  
- *Bearings description :* 2 cylindrical bearings on LS shaft  
2 offset bearings on HS shaft  
1 double acting tilting pad thrust bearing on low speed shaft non driven end
  
- *Mechanical running test :* Full speed, no load test during 4 hours according to the API 613 5th Edition standard.
  
- *Lubrication conditions :* 164 l/min of Oil ISO VG 46 at 60°C and 2.5 bar at inlet (calculated values only)
  
- *Miscellaneous:* Efficiency at full load : 99.03 %  
Power losses at full load : 66 kW (calculated value only)  
Anticipated Sound Pressure Level: 82.0 ± 2dB(A) at 1 meter

**Base price :** 117 900 EUR each gear box  
**Delivery time :** 36 weeks after the FG acknowledgement of the order  
**Quantity :** 8 gearboxes

### Comments :

- Coupling data taken into account on HS Shaft:
  - o Weight: 26.6 kg
  - o Center of gravity position from shaft end: 30.9 mm
  - o Inertia: 0.266 kgm<sup>2</sup>
- Coupling data taken into account on LS Shaft:
  - o Weight: 87.5 kg
  - o Center of gravity position from shaft end: 40.9 mm
  - o Inertia: 0.875 kgm<sup>2</sup>

### Including :

- Customer witness of test
- After test disassembly and inspection
- Noise level test report
- Lateral analysis undamped
- Documentation : downloadable electronic file in english

### Instrumentation (see the complete package on additional technical data sheet):

- *Temperature package*  
12 RTD's PT100 Duplex 3 wires from Thermo Electric Company Inc.  
(2 per bearing and thrust bearing side) not wired with terminal heads..... Price included
- *Bently Nevada vibration package*  
8 radial (4 per shaft) & 2 axial (on LS shaft) vibration probes, 2 accelerometers (1 per shaft), 2  
keyphasors (1 per shaft) not wired ..... Price included

### Spare parts (Prices are net valid only if spares are ordered together with the gearbox):

- *Commissioning Spares*  
2 RTD's, 2 BN vibration probes, 2 BN accelerometers ..... 7 900 EUR Lot Net
- *2 Years Normal Operation Spares*  
2 set of bearings with RTD's, 1 set of oil seals ..... 48 420 EUR Lot Net
- *Strategic Spare Parts*  
One complete set of rotating elements consisting of one pinion and one gear.  
Tested if ordered together with the main gearbox according to API613/03  
Full Speed, No Load, with Test Report..... 51 500 EUR Lot Net
- *Container for horizontal spare rotors storage painted according FG standard..... 17 100 EUR Lot Net*

**SPECIAL PURPOSE GEAR UNITS**  
**API 613 FIFTH EDITION**  
**DATA SHEET SI UNITS**

Job No. 41104 Item No. A  
 P.O. No. \_\_\_\_\_ Date \_\_\_\_\_  
 Requisition No. \_\_\_\_\_  
 Inquiry No. \_\_\_\_\_  
 Revision 1 Date 06.03.2015 By HNI

<p>1 Applicable To: <input checked="" type="radio"/> Proposal <input type="radio"/> Purchase <input type="radio"/> As Built</p> <p>2 For <u>Siemens AG Dulsburg</u></p> <p>3 Site <u>Khursanlyah Al Fadhill</u></p> <p>4 Unit <u>STC-SV 08-4-A</u></p> <p>5 Service <u>EM/CC</u></p> <p>6 No. required <u>9</u></p>	<p><input type="radio"/> US Standards (1.7) <input checked="" type="radio"/> ISO Standards (1.7)</p> <p>Manufacturer <u>FLENDER-GRAFFENSTADEN</u></p> <p>Model No. <u>TX50/4C</u></p> <p>Serial No. _____</p> <p>Driver type <u>electric motor</u></p> <p>Driven equipment <u>centrifugal compressor</u></p>
<p><b>NOTE : Numbers within ( ) refer to applicable API standard 613 paragraphs</b></p>	
<p><input type="checkbox"/> Information to be completed by purchaser <span style="margin-left: 100px;"><input type="checkbox"/> Information to be completed by manufacturer</span></p>	
<p><input type="checkbox"/> UNITS OF MEASUREMENT</p>	<p><input checked="" type="checkbox"/> BASIC GEAR DATA</p>
<p><input type="checkbox"/> US Customary units</p> <p><input checked="" type="checkbox"/> SI units</p> <p style="text-align: center;"><b>○ RATING REQUIREMENTS</b></p> <p>14 Driven equip. (2.1.4): Norm. _____ Max _____ kW</p> <p>15 Driver: Rated _____ Max _____ kW</p> <p>16 Normal transmitted power (2.2.2) _____ kW</p> <p>17 Gear unit rated power (2.2.1) <u>6800</u> kW</p> <p>18 Torque @ max cont speed _____ Nm</p> <p>19 Max torque (2.2.1) _____ Nm @ _____ rpm</p> <p>20 <input type="checkbox"/> Reducer <input checked="" type="checkbox"/> Increaser</p> <p>21 Rated speed (2.1.5):</p> <p>22 Input <u>1800</u> rpm <input type="checkbox"/> Specified <input checked="" type="checkbox"/> Nominal</p> <p>23 Output <u>7285</u> rpm <input type="checkbox"/> Specified <input checked="" type="checkbox"/> Nominal</p> <p>24 Allow var in gear ratio (2.1.6) (+) (-) _____ %</p> <p>25 Max continuous speed (1.5) <u>1800 / 7285</u> rpm</p> <p>26 Trip speed (1.5) (2.1.7) <u>1980 / 8013,5</u> rpm</p> <p>27 Gear service factor (2.2.3.1) <u>1,4 API 613/2003 5 TH</u> (min)</p> <p>28 Hardness (2.2.3.2) Pinion _____ Gear _____</p> <p>29 Shaft assembly designation (2.1.19) _____ L/R</p> <p>30 HS shaft rot fac'g cpl'g (2.1.20.2) <input checked="" type="checkbox"/> CW <input type="checkbox"/> CCW</p> <p>31 LS shaft rot fac'g cpl'g (2.1.20.2) <input checked="" type="checkbox"/> CW <input type="checkbox"/> CCW</p> <p>32 External loads (2.1.16) _____</p> <p>33 Other operating conditions (2.2.2) (2.6.1.3) _____</p>	<p><input checked="" type="radio"/> Single stage <input type="radio"/> Single helical</p> <p><input type="radio"/> Double stage <input checked="" type="radio"/> Double helical</p> <p><input type="radio"/> Epicyclic <input type="radio"/> horizontal offset</p> <p>Mechanical rating (1.5.16) <u>9520</u> kW @ <u>1800 / 7309,1</u> rpm</p> <p>Gear service factor (2.2.3.1) <u>1,44 API 613/2003 5 TH</u> (actual)</p> <p>Full load gear unit power loss _____ kW</p> <p>Gear Unit Mechanical efficiency <u>99,03</u> %</p> <p>Rating speed Pinion <u>7,309,1</u> Gear <u>1,800,0</u> rpm</p> <p>Hardness used for</p> <p>Rating, (HB or Rc) Pinion <u>58 HRC</u> Gear <u>58 HRC</u></p> <p>Tooth pitting index, "K" (2.2.4.1) (2.2.4.2)</p> <p style="text-align: center;">Allowable <u>2,17</u> Actual <u>2,10</u> MPa</p> <p>Material index number (Fig 3, Table 4) <u>3,03</u> MPa</p> <p>Bending stress number, "S<sub>b</sub>" (2.2.5.1) (2.2.5.2)</p> <p>Pinion: Allowable <u>265,4</u> Actual <u>256,0</u> MPa</p> <p>Gear: Allowable <u>265,4</u> Actual <u>240,9</u> MPa</p> <p>Pitch line velocity <u>77,1</u> m/s</p> <p>Anticipated SPL (2.1.6) <u>82</u> dB(A) @ <u>1</u> m</p> <p>WR<sup>2</sup> referred to LS shaft <u>126,12</u> kgm<sup>2</sup></p> <p>Breakaway torque <u>412</u> Nm @ LS Shaft</p> <p>Pinion teeth hardness range <u>58 - 63 HRC</u></p> <p>Pinion teeth hardening method <u>CARBURIZED</u></p> <p><input type="checkbox"/> HS shaft separate hardness range _____</p> <p>Gear teeth (rim) hardness range <u>58 - 63 HRC</u></p> <p>Gear teeth hardening method <u>CARBURIZED</u></p> <p>Gear hub:</p> <p><input checked="" type="checkbox"/> Forged cylinder <input type="checkbox"/> Forged &amp; Copped <input type="checkbox"/> Fabricated</p> <p>Gear to Shaft fit method (2.5.3.2)</p> <p><input type="checkbox"/> Integral <input type="checkbox"/> Keyed interference <input checked="" type="checkbox"/> Keyless interference</p> <p>Rim attachment (2.5.3.2) <u>FORGED GEAR WHEEL</u></p> <p>LS shaft hardness range <u>HB 230 - 274</u></p> <p>Journal static weight loads (2.6.6.3)</p> <p>Pinion <u>128 / 42</u> kg Gear <u>942 / 707</u> kg</p> <p>Total gear unit assembled weight <u>4000</u> kg</p> <p>NOTES : _____</p>
<p><b>○ INSTALLATION DATA (2.1.14)</b></p>	
<p>36 <input type="checkbox"/> Indoor <input type="checkbox"/> Heated <input type="checkbox"/> Under roof</p> <p>37 <input checked="" type="checkbox"/> Outdoor <input type="checkbox"/> Unheated <input type="checkbox"/> Partial sides</p> <p>38 <input type="checkbox"/> Grade <input type="checkbox"/> Mazzanine <input checked="" type="checkbox"/> <b>ONSHORE</b></p> <p>39 <input type="checkbox"/> Winterization required <input type="checkbox"/> Tropicalization required</p> <p>40 Electrical area (2.1.10) Class _____ Grp _____ Div _____</p> <p>41 Electrical area (2.1.10) Zone <u>2</u> Grp <u>IIA</u> Temp <u>T1</u> °C</p> <p>42 Max allow SPL (2.1.6) _____ dB(A) @ _____ m</p> <p>43 Elevation _____ m Barometer _____ kPa abs</p> <p>44 Range of ambient temperatures:</p> <p>45 Dry bulb _____ Wet bulb _____</p> <p>46 Normal _____ °C _____ °C</p> <p>47 Maximum <u>82</u> °C _____ °C</p> <p>48 Minimum <u>0</u> °C _____ °C</p> <p>49 Unusual conditions <input type="checkbox"/> Dust <input type="checkbox"/> Fumes</p> <p>60 <input type="checkbox"/> _____</p>	

**SPECIAL PURPOSE GEAR UNITS**  
**API 613 FIFTH EDITION**  
**DATA SHEET SI UNITS**

Job No. 41104 Item No. A  
P.O. No. \_\_\_\_\_ Date \_\_\_\_\_  
Requisition No. \_\_\_\_\_  
Inquiry No. \_\_\_\_\_  
Revision 1 Date 06.03.2015 By HNI

■ GEAR DATA				○ COUPLINGS AND GUARDS		
	Pinion	Gear		Pinion	Gear	
3	Number of teeth	<u>33</u>	<u>134</u>	Coupling furnished by (3.2.1)	<u>Compr. Supplier</u>	<u>Compr. Supplier</u>
4	Gear ratio	<u>4,06</u>		Mount coupling halves (3.2.2)	<u>Compr. Supplier</u>	<u>Compr. Supplier</u>
5	Tangential load, "Wt" (2,2,4,2)	<u>88.155</u>		Cplg. guard adapter by (3.2.3)	<u>Gear Supplier</u>	<u>Gear Supplier</u>
6	AGMA Geometry factor "J"	<u>0,55</u>	<u>0,57</u>	Cplg. guard furnished by (3.2.3)	<u>Compr. Supplier</u>	<u>Compr. Supplier</u>
7	Pitch diameter	<u>201,56</u>	<u>818,44</u>	Coupling vendor (3.2.3)		
8	Outside diameter	<u>214,10</u>	<u>827,60</u>	Vendor's model number (3.2.3)		
9	Root diameter	<u>187,25</u>	<u>800,74</u>	Coupling weight on shaft, kg	<u>26,6</u>	<u>87,5</u>
10	Center groove diameter	<u>177,00</u>	<u>790,00</u>	CG inboard / outboard of shaft end	<u>Outboard</u>	<u>Outboard</u>
11	Normal pressure angle	<u>20,00</u>		Hub drill template provided	<input type="checkbox"/>	<input type="checkbox"/>
12	Normal diametral pitch	<u>4,62</u>		■ SHAFT END DETAIL (2.5.4.2)		
13	Helix angle	<u>25,00</u>		Shaft end detail specified by: <input checked="" type="radio"/> Purchaser <input type="radio"/> Gear vendor		
14	Center distance	<u>510,00</u>		(Integral unless otherwise specified)		
15	Backlash min	<u>0,34</u>		Shaft end detail if 'otherwise' specified:		
16	Net face width, "Fw"	<u>260,00</u>		Pinion	Gear	
17	Pinion L/D	<u>1,71</u>		Tapered / Keyless	<input type="radio"/>	<input type="checkbox"/>
18	Face overlap ratio	<u>6,36</u>		Tapered / 1-Key	<input type="radio"/>	<input type="checkbox"/>
19	Transverse contact ratio	<u>1,45</u>		Tapered / 2-Keys	<input type="radio"/>	<input type="checkbox"/>
20	AGMA 6011 service factor	<u>2,64</u>		Cylindrical / 1-Key	<input type="radio"/>	<input type="checkbox"/>
21	Rating based on ANSI/AGMA 6011 with SF=1.0			Cylindrical / 2-Keys	<input type="radio"/>	<input type="checkbox"/>
22	Durability Power	<u>21442</u>		Other <u>Flanged</u>	<input checked="" type="radio"/>	<input type="checkbox"/>
23	Strength Power	<u>17946</u>		Shaft diameter	<u>120,0</u>	<u>190,0</u>
24	Tooth Surface Finish, Ra	<u>0,4</u>	<u>0,4</u>	(if integral flange use diameter immediately adjacent to flange)		
25	Tooth Generation Process	<u>Hobbling</u>	<u>Hobbling</u>	■ RADIAL BEARINGS		
26	Tooth Finishing Process	<u>Grinding</u>	<u>Grinding</u>	Type	<u>OFFSET / OFFSET</u>	<u>CYL. / CYL.</u>
27	Lead modification (2.2.4.6)	<input checked="" type="radio"/> Not Req'd	<input type="radio"/> Req'd	Diameter	<u>130 / 130</u>	<u>200 / 200</u>
28	Calculated Total Lead Mismatch			Length	<u>130 / 130</u>	<u>100 / 100</u>
29				Journal velocity	<u>49,8 / 49,8</u>	<u>18,8 / 18,8</u>
30	■ SCUFFING DATA (2.2.6)			Loading	<u>2,78 / 2,81</u>	<u>2,87 / 2,71</u>
31	Scuffing Data per ANSI/AGMA 926-A03			Clearance (min-max)		
32	Scuffing Risk (2.2.6) <=5% (Low)	Calculation Method	<u>AGMA925</u>	Span	<u>550</u>	<u>550</u>
33	Composite surface roughness, $\sigma_x$	<u>0,57</u>		Power loss each bearing	<u>13,8 / 13,8</u>	<u>3,0 / 3,0</u>
34	Specific film thickness, EHL $A_{min}$	<u>3,31</u>		Oil flow each bearing	<u>42,0 / 42,0</u>	<u>10,0 / 10,0</u>
35	Tooth temperature, $\theta_m$	<u>82</u>		■ THRUST BEARINGS		
36	Maximum contact temperature, $\theta_{Bmax}$	<u>101</u>		Location	<u>OPP.CPLG.SIDE</u>	
37				Manufacturer	<u>FLENDER</u>	
38	■ MATERIALS			Type	<u>NO</u>	
39	Gear casing	<u>Steel</u>	Oil seals <u>aluminium</u>	Size	<u>BPK LEG 6"</u>	
40	Pinion(s)	<u>18CrNiMo7-6</u>		Area	<u>11615</u>	
41	Gear rim(s)	<u>18CrNiMo7-6</u>		Loading	<u>1,14</u>	
42	HS Shaft	<u>Integral</u>	LS Shaft <u>42CrMo4</u>	Rating	<u>1,50</u>	
43	Radial bearings	<u>Babbitt</u>	Backing <u>Steel</u>	Int. thrust load	<u>N</u>	
44	Thrust bearing(s)	<u>Babbitt</u>	Backing <u>Steel</u>	Ext. thrust load	<u>4,050</u>	<u>9,200</u>
45				Power loss each	<u>0,0</u>	<u>6,0</u>
46	○ SHAFT END DETAIL			Oil flow each bearing	<u>0,0</u>	<u>20,0</u>
47	<input checked="" type="checkbox"/> Gear shaft end for coupling integral flange (2.5.4.2)			NOTES : _____		
48	<input checked="" type="checkbox"/> Pinion shaft end for coupling integral flange (2.5.4.2)					
49	<input checked="" type="checkbox"/> Other : <u>WITHOUT BOLTS</u>					

**SPECIAL PURPOSE GEAR UNITS**  
**API 613 FIFTH EDITION**  
**DATA SHEET SI UNITS**

1 **○ LUBRICATION REQUIREMENTS**

2  Oil system furnished by (2.8.3) \_\_\_\_\_

3  Other \_\_\_\_\_  Gear vendor \_\_\_\_\_

4  Oil visc. \_\_\_\_\_ cp @ 40°C \_\_\_\_\_ cp @ 100°C (2.8.6)

5  ISO Grade \_\_\_\_\_ Load stage (2.2.6) **5,0**

6 **■ MESH**

7

8 Mesh and windage power loss **26,4** kW

9 Oil flow, mesh **40,0** l/min

10

11 **■ LUBRICATION REQUIREMENTS**

12 Min. startup oil temperature **20,0** °C

13 Normal oil inlet temperature **60,0** °C

14 Maximum oil inlet temperature **65,0** °C

15 Unit oil flow (total) **164,0** l/min

16 Unit oil pressure **2,5** bar

17  Oil visc. \_\_\_\_\_ cp @ 40°C \_\_\_\_\_ cp @ 100°C (2.8.6)

18  ISO Grade **46** Load stage (2.2.6) **5,0**

19

20 **■ PIPING CONNECTIONS**

Service	No.	Size	Type
Lube oil inlet	1	2 in.	ANSI 150 LBS
Lube oil outlet	1	6 in.	ANSI 150 LBS
Casing drain *			
Vent	1	1,5 in.	ANSI 150 LBS
Casing purge			

27 \* Casing drain is 'dead bottom' housing drain, not lube oil outlet

28 **○ MOUNTING PLATES**

29  Gear furnished with (3.3.1.1)

30  Baseplate  Soleplate  Subplate(s) (3.3.2.10)

31  Mounting plates(s) furnished by (3.3.1.1) \_\_\_\_\_

32  Baseplate leveling (3.3.2.3) \_\_\_\_\_

33  Baseplate with leveling pads (3.3.2.3)

34  Baseplate suitable for column mounting (3.3.2.4)

35  Vendor review of purchaser's foundation dwgs. (2.1.13)

36  Grout type (3.3.1.2.4) \_\_\_\_\_

37

38 **○ CONTRACT DATA**

39  Test data prior to shipment \_\_\_\_\_

40  Progress report (5.3.3) \_\_\_\_\_

41  Vendor signoff of inspector checklist (4.1.1.3)

42  Information retained for 20 years (4.2.1.1) (4.2.2.6.1)

43  Technical manual (5.3.5.4)

44  PAINTING (4.4.3.1)  Flender standard RAL5015 (blue)

45  Painting housing interior not allowed (2.3.1.14)

46 **○ SHIPMENT**

47  Steel rotor storage container (4.4.5)  Shaft covers (4.4.4)

48 Contract unit \_\_\_\_\_ Spares \_\_\_\_\_

49 Export boxing  \_\_\_\_\_

50 Domestic boxing  \_\_\_\_\_

51 Outdoor storage over 6 mos.  3 years indoor  (4.4.3.9)

Job No. **41104** Item No. **A**

P.O. No. \_\_\_\_\_ Date \_\_\_\_\_

Requisition No. \_\_\_\_\_

Inquiry No. \_\_\_\_\_

Revision **1** Date **06.03.2015** By **HNI**

**○ ADDITIONAL REQUIREMENTS**

**○ VIBRATION DETECTORS**

**RADIAL (3.4.2.1) (2.7.4.5) (2.7.4.6)**

Manufacturer **BENTLY NEVADA**  Total No. **8**

X-Y probes pinion bearings  Coupling end  Blind end

X-Y probes gear bearings  Coupling end  Blind end

Other \_\_\_\_\_

**AXIAL (3.4.2.1) (2.7.4.5) (2.7.4.6)**

Manufacturer **BENTLY NEVADA**  Total No. **2**

Dual probes at each thrust bearing

Single probe any shaft without thrust bearing

Other \_\_\_\_\_

**ONE EVENT PER REVOLUTION PROBE (2.7.4.5) (2.7.4.6)**

Manufacturer **BENTLY NEVADA** Total No. **2**

One on input shaft  One on output shaft

Other \_\_\_\_\_

**ACCELEROMETER (3.4.2.1) (2.7.4.5) (2.7.4.6)**

Manufacturer **BENTLY NEVADA**  No. required **2**

Pinion coupling end  Gear coupling end

Other \_\_\_\_\_

**○ TEMPERATURE DETECTORS**

Dial type thermometers (3.4.2.7) \_\_\_\_\_

Type brg. temp. sensors (3.4.2.7) (2.7.1.3) **PT100**

RTD  Thermocouple /  Simplex  Duplex

Calibration **Yes**

HSALS bearings no. sensors each **2** / **2**

Thrust number of sensing elements each face **2**

**○ OTHER VIBRATION AND TEMPERATURE**

(3.4.2.5) (3.4.2.6) Other Gear vendor

Oscillator demodulator supplied by

Vibration monitor supplied by

Vibration shutdown delay time \_\_\_\_\_ seconds

Temperature monitor supplied by

Oscillator demodulator J-box by

Temp. sensor termination J-box by

J-box type \_\_\_\_\_ Mount \_\_\_\_\_

**○ MISCELLANEOUS**

Undamped critical analysis report (2.6.2.1)

w/ dampd rotr respsn analys rpt (2.6.2.4.3) (2.6.2.6)

Torsional analysis by (2.6.5.2)  Gear vendor  Other

Spare set of gear rotors (4.3.2.4)

Gear case furnished with inlet purge connection (2.4.3)

Orientation of oil inlet & drain conns. (2.4.6) \_\_\_\_\_

Filter breather location (2.3.1.12) **Prov. on upper casing**

Torsional device provisions (2.5.4.5) \_\_\_\_\_

Rotor vertical storage provisions (2.5.4.8) \_\_\_\_\_

Rotor vertical storage fixture(s) (3.6.2) \_\_\_\_\_

Vendor service rep. on site (2.1.13)



**PRELIMINARY MASS ELASTIC DATA**

Customer : Siemens AG Duisburg  
 Destination : Khursariyah Al Fadhili  
 Purchaser order :  
 F-G job number : D 41104A1 OL  
 Type and serial N° : TX50/4C

Power rating : 6800 kW  
 Service factor : AP1613.03 >=1,4  
 Input speed : 1800 rpm  
 Output speed : 7309,1 rpm  
 Speed ratio : 4,06

Weight HSS : 143,5 kg  
 Weight pos. from tooth middle HSS : -63,4 mm  
 Inertia HSS : 0,585 Kg.m²  
 Stiffness HSS : 5,916 MN/mrd  
 Bearing type 1 : Offset 130 x 130  
 Bearing type 2 : Offset 130 x 130  
 Add. weight on brg. side 1 : 26,6 kg

Weight LSS : 1561,2 kg  
 Weight pos. from tooth middle LSS : 10,5 mm  
 Inertia LSS : 116,473 Kg.m²  
 Stiffness LSS : 39,014 MN/mrd  
 Bearing type 4 : Cylindrical 200 x 100  
 Bearing type 3 : Cylindrical 200 x 100  
 Add. weight on brg. side 4 : 87,5 kg



Positive direction of external

APPAREIL\_xis\_ Edition du :06.03.2015  
 1/1

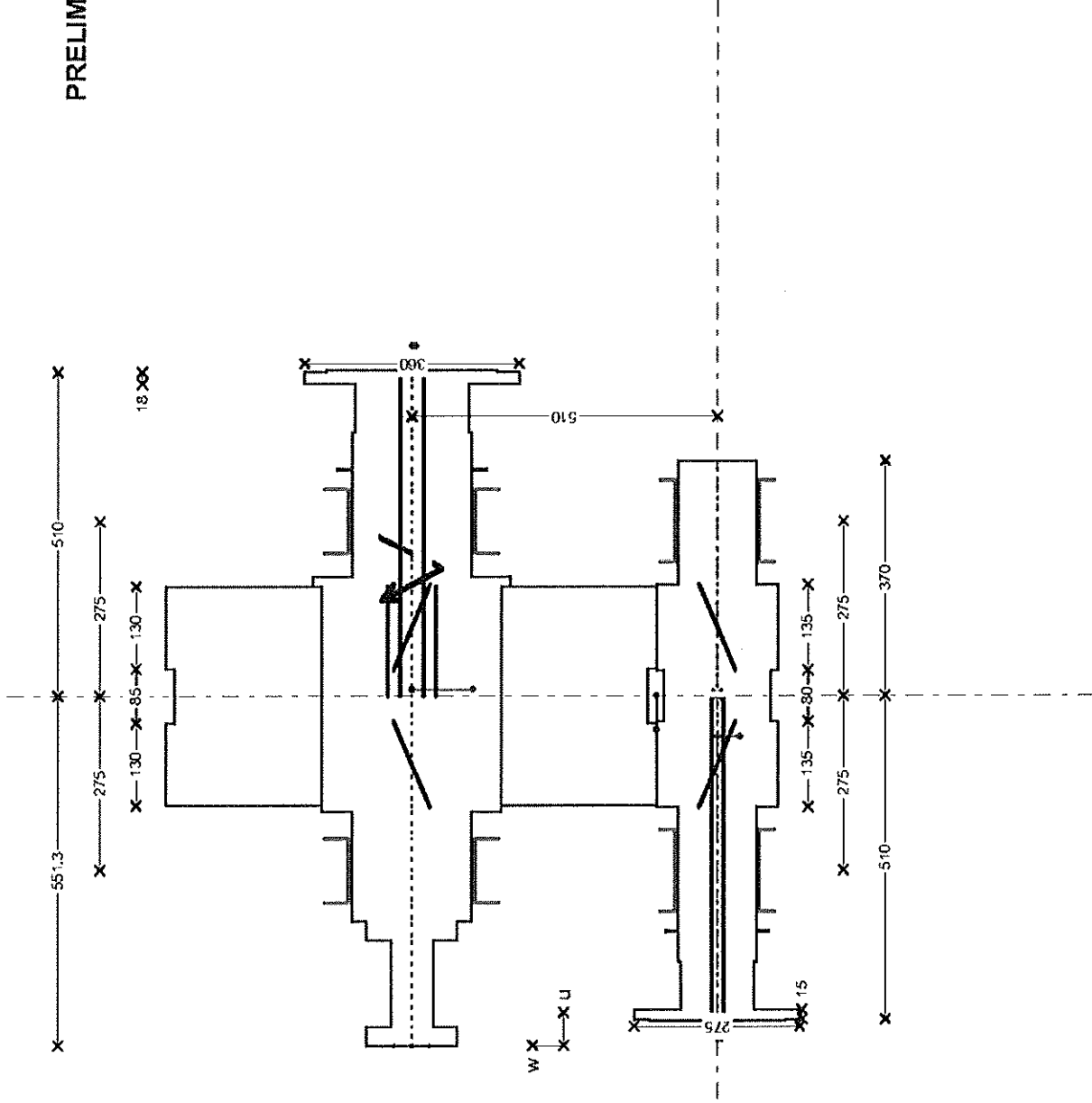

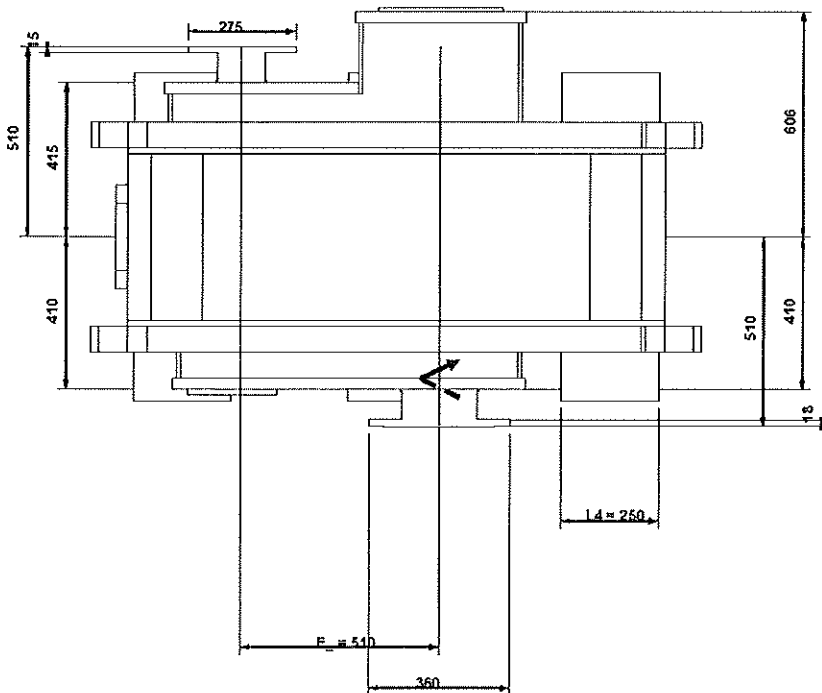
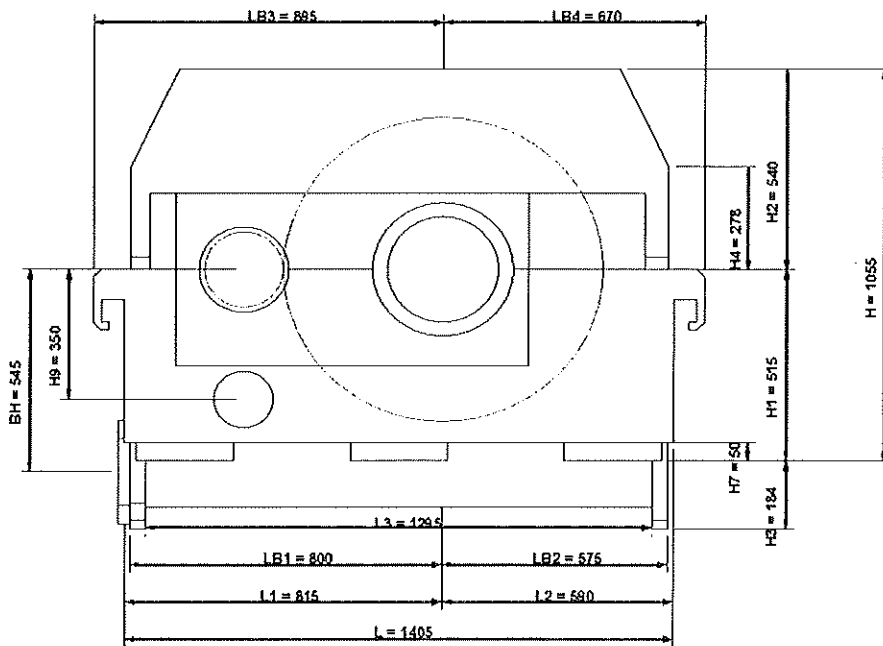



<b>ADDITIONAL TECHNICAL DATASHEET</b>		Job No. <u>41104</u> Item No. <u>A</u>																																			
		P.O. No. _____ Date _____																																			
		Requisition No. _____																																			
		Inquiry No. _____																																			
		Revision <u>1</u> Date <u>06.03.2016</u> By <u>HNI</u>																																			
<input checked="" type="checkbox"/> <b>ADDITIONAL GEAR DATA</b>		<input type="checkbox"/> <b>TURNING GEAR (Dimensioning is preliminary !)</b>																																			
<i>Efficiency</i>		<i>Calculation results</i>																																			
<table border="1" style="width:100%; border-collapse: collapse;"> <thead> <tr> <th>Percent of rated power</th> <th>Efficiency</th> </tr> </thead> <tbody> <tr> <td>100%</td> <td style="text-align: center;"><b>99,03</b></td> </tr> <tr> <td>75%</td> <td style="text-align: center;"><b>98,92</b></td> </tr> <tr> <td>50%</td> <td style="text-align: center;"><b>98,79</b></td> </tr> <tr> <td>25%</td> <td style="text-align: center;"><b>98,08</b></td> </tr> <tr> <td>10%</td> <td style="text-align: center;"><b>90,80</b></td> </tr> </tbody> </table>		Percent of rated power	Efficiency	100%	<b>99,03</b>	75%	<b>98,92</b>	50%	<b>98,79</b>	25%	<b>98,08</b>	10%	<b>90,80</b>	Required turning speed _____ rpm Actual turning speed _____ rpm Required breakaway torque _____ Nm Actual breakaway torque _____ Nm Actual maximum torque _____ Nm Actual acceleration time _____ s																							
Percent of rated power	Efficiency																																				
100%	<b>99,03</b>																																				
75%	<b>98,92</b>																																				
50%	<b>98,79</b>																																				
25%	<b>98,08</b>																																				
10%	<b>90,80</b>																																				
<i>Losses</i>		<i>Motor</i>																																			
Power loss at no load _____ kW Heat rejection _____ kcal/h		Supplier _____ Power _____ kW Voltage _____ V Frequency _____ Hz Speed _____ rpm Electric standard _____																																			
<input type="checkbox"/> <b>PUMP DETAILS (Dimensioning is preliminary !)</b>																																					
Design : _____ Speed : _____ rpm Oil flow : _____ l/min Oil pressure : _____ bar NPSH : _____ m Safety valve : _____ Driving method : _____ Material : _____ Flanges : _____ Testing : _____ Furniture of ATEX certificate : _____		<table border="1" style="width:100%; border-collapse: collapse;"> <thead> <tr> <th colspan="2" style="text-align: center;"><i>Turning gear</i></th> </tr> </thead> <tbody> <tr> <td>Type</td> <td>_____</td> </tr> <tr> <td>Ratio</td> <td>_____</td> </tr> </tbody> </table> <table border="1" style="width:100%; border-collapse: collapse;"> <thead> <tr> <th colspan="2" style="text-align: center;"><i>Clutch</i></th> </tr> </thead> <tbody> <tr> <td>Type</td> <td>_____</td> </tr> <tr> <td>Max. allowable torque</td> <td>_____ Nm</td> </tr> </tbody> </table> <table border="1" style="width:100%; border-collapse: collapse;"> <thead> <tr> <th colspan="2" style="text-align: center;"><i>Miscellaneous</i></th> </tr> </thead> <tbody> <tr> <td>Starting device</td> <td>_____</td> </tr> <tr> <td>Switch details</td> <td>_____</td> </tr> </tbody> </table>	<i>Turning gear</i>		Type	_____	Ratio	_____	<i>Clutch</i>		Type	_____	Max. allowable torque	_____ Nm	<i>Miscellaneous</i>		Starting device	_____	Switch details	_____																	
<i>Turning gear</i>																																					
Type	_____																																				
Ratio	_____																																				
<i>Clutch</i>																																					
Type	_____																																				
Max. allowable torque	_____ Nm																																				
<i>Miscellaneous</i>																																					
Starting device	_____																																				
Switch details	_____																																				
<input checked="" type="checkbox"/> <b>INSTRUMENTATION PACKAGE</b>																																					
<i>Thermometer</i>		<i>Thermoelements</i>																																			
<table border="1" style="width:100%; border-collapse: collapse;"> <thead> <tr> <th></th> <th>Bearing</th> <th>Thrust bearing</th> <th>Oil inlet/outlet</th> </tr> </thead> <tbody> <tr> <td>Qty</td> <td></td> <td></td> <td></td> </tr> <tr> <td>Type</td> <td></td> <td></td> <td></td> </tr> </tbody> </table>			Bearing	Thrust bearing	Oil inlet/outlet	Qty				Type				<table border="1" style="width:100%; border-collapse: collapse;"> <thead> <tr> <th></th> <th>Bearing</th> <th>Thrust bearing</th> <th>Oil inlet/outlet</th> </tr> </thead> <tbody> <tr> <td>Type</td> <td>DUPLEX 2x3F</td> <td>DUPLEX 2x3F</td> <td></td> </tr> <tr> <td>Classification</td> <td>IEC60751</td> <td>IEC60751</td> <td></td> </tr> <tr> <td>Removable from the outside</td> <td>NO</td> <td>NO</td> <td></td> </tr> <tr> <td>ATEX</td> <td>ATEX Eexia</td> <td>ATEX Eexia</td> <td></td> </tr> </tbody> </table>		Bearing	Thrust bearing	Oil inlet/outlet	Type	DUPLEX 2x3F	DUPLEX 2x3F		Classification	IEC60751	IEC60751		Removable from the outside	NO	NO		ATEX	ATEX Eexia	ATEX Eexia				
	Bearing	Thrust bearing	Oil inlet/outlet																																		
Qty																																					
Type																																					
	Bearing	Thrust bearing	Oil inlet/outlet																																		
Type	DUPLEX 2x3F	DUPLEX 2x3F																																			
Classification	IEC60751	IEC60751																																			
Removable from the outside	NO	NO																																			
ATEX	ATEX Eexia	ATEX Eexia																																			
<i>Shaft vibrations</i>																																					
<table border="1" style="width:100%; border-collapse: collapse;"> <thead> <tr> <th></th> <th>Radial</th> <th>Axial</th> <th>Keyphasor</th> <th>Accelerometer</th> </tr> </thead> <tbody> <tr> <td>Type</td> <td>B.N. 3300 XL 8mm Sys. 9M</td> <td>HS No LS BENTLY NEVADA 3300 XL 8mm Sys. 9M</td> <td>B.N. 3300 XL 8mm Sys. 9M</td> <td>ACCELEROMETER BENTLY</td> </tr> <tr> <td>Probe</td> <td>Yes</td> <td>HS No LS Yes</td> <td>Yes</td> <td></td> </tr> <tr> <td>Proximitior</td> <td>Yes</td> <td>HS No LS Yes</td> <td>Yes</td> <td style="background-color: #cccccc;"></td> </tr> <tr> <td>Probe holder</td> <td>Yes</td> <td>HS No LS Yes</td> <td>Yes</td> <td style="background-color: #cccccc;"></td> </tr> <tr> <td>Connection head</td> <td>Yes</td> <td>HS No LS Yes</td> <td>Yes</td> <td style="background-color: #cccccc;"></td> </tr> <tr> <td>mounting kit</td> <td style="background-color: #cccccc;"></td> <td style="background-color: #cccccc;"></td> <td style="background-color: #cccccc;"></td> <td>Yes</td> </tr> </tbody> </table>				Radial	Axial	Keyphasor	Accelerometer	Type	B.N. 3300 XL 8mm Sys. 9M	HS No LS BENTLY NEVADA 3300 XL 8mm Sys. 9M	B.N. 3300 XL 8mm Sys. 9M	ACCELEROMETER BENTLY	Probe	Yes	HS No LS Yes	Yes		Proximitior	Yes	HS No LS Yes	Yes		Probe holder	Yes	HS No LS Yes	Yes		Connection head	Yes	HS No LS Yes	Yes		mounting kit				Yes
	Radial	Axial	Keyphasor	Accelerometer																																	
Type	B.N. 3300 XL 8mm Sys. 9M	HS No LS BENTLY NEVADA 3300 XL 8mm Sys. 9M	B.N. 3300 XL 8mm Sys. 9M	ACCELEROMETER BENTLY																																	
Probe	Yes	HS No LS Yes	Yes																																		
Proximitior	Yes	HS No LS Yes	Yes																																		
Probe holder	Yes	HS No LS Yes	Yes																																		
Connection head	Yes	HS No LS Yes	Yes																																		
mounting kit				Yes																																	
<i>Junction box(es)</i>		<i>Miscellaneous</i>																																			
Qty <u>0</u> Manufacturer _____ Material _____ ATEX <u>None</u>		Identification <input checked="" type="checkbox"/> wire <input checked="" type="checkbox"/> conduit <input type="checkbox"/> junction box Conduit type _____ Transmitter type _____ Qty _____ Terminal block type _____ Qty _____																																			

# FLENDER GRAFFENSTADEN

FLENDER-GRAFFENSTADEN S.A., FRANCE  
BP 84, F-67402 ILLKIRCH-CEDEX  
1, rue du Vieux Moulin  
F-67400 ILLKIRCH-GRAFFENSTADEN

Y/ref : Khursaniyah Al Fadhili - D43-K-3801 -  
O/ref : D41104 quotation number 3

## ITEM B 1 : Flender Graffenstaden (FG) High Speed increaser, model **TX40/5C**

- *Rating conditions :* Rated power at **1620 kW**  
Driven by a electric motor at **1800.0 rpm** (specified : 1800.0 rpm)  
Driving a centrifugal compressor at **10737.9 rpm** (specified : 10736.0 rpm)  
Service factor **1.47** according to **API613/03** (required : > 1.4)
  
- *Technical description :* Double helical  
Manufacturing according to API standard  
Flange on LS shaft end  
Flange on HS shaft end  
Estimated Weight : 1900 kg
  
- *Bearings description :* 2 cylindrical bearings on LS shaft  
2 tilting pads bearings on HS shaft  
1 double acting tilting pad thrust bearing on low speed shaft non driven end
  
- *Mechanical running test :* Full speed, no load test during 4 hours according to the API 613 5th Edition standard.
  
- *Lubrication conditions :* 64 l/min of Oil ISO VG 46 at 60°C and 2.5 bar at inlet (calculated values only)
  
- *Miscellaneous:* Efficiency at full load : 98.70 %  
Power losses at full load : 21 kW (calculated value only)  
Anticipated Sound Pressure Level: 82.0 ± 2dB(A) at 1 meter

**Base price :** 103 850 EUR each gear box

**Delivery time :** 36 weeks after the FG acknowledgement of the order

**Quantity :** 1 gearbox

## Comments :

- Coupling data taken into account on HS Shaft:
  - o Weight: 10.4 kg
  - o Center of gravity position from shaft end: 28.2 mm
  - o Inertia: 0.104 kgm<sup>2</sup>
- Coupling data taken into account on LS Shaft:
  - o Weight: 26.4 kg
  - o Center of gravity position from shaft end: 30.9 mm
  - o Inertia: 0.264 kgm<sup>2</sup>

## Including :

- Customer witness of test
- After test disassembly and inspection
- Noise level test report
- Lateral analysis undamped
- Documentation : downloadable electronic file in English

## Instrumentation (see the complete package on additional technical data sheet):

- *Temperature package*  
12 RTD's PT100 Duplex 3 wires from Thermo Electric Company Inc.  
(2 per bearing and thrust bearing side) not wired with terminal heads..... Price included
- *Bently Nevada vibration package*  
8 radial (4 per shaft) & 2 axial (on LS shaft) vibration probes, 2 accelerometers (1 per shaft), 2 keyphasors (1 per shaft) not wired ..... Price included

## Spare parts (Prices are net valid only if spares are ordered together with the gearbox):

- *Commissioning Spares*  
2 RTD's, 2 BN vibration probes, 2 BN accelerometers ..... 7 900 EUR Lot Net
- *2 Years Normal Operation Spares*  
1 set of bearings with RTD's, 1 set of oil seals ..... 26 010 EUR Lot Net
- *Strategic Spare Parts*  
One complete set of rotating elements consisting of one pinion and one gear.  
Tested if ordered together with the main gearbox according to API613/03  
Full Speed, No Load, with Test Report..... 37 100 EUR Lot Net
- *Container for horizontal spare rotors storage painted according FG standard..... 15 850 EUR Lot Net*

**SPECIAL PURPOSE GEAR UNITS**  
**API 613 FIFTH EDITION**  
**DATA SHEET SI UNITS**

Job No. 41104 item No. B  
 P.O. No. \_\_\_\_\_ Date \_\_\_\_\_  
 Requisition No. \_\_\_\_\_  
 Inquiry No. \_\_\_\_\_  
 Revision 1 Date 06.03.2015 By HNI

Applicable To:  Proposal  Purchase  As Built  
 US Standards (1.7)  ISO Standards (1.7)

For Siemens AG Dulsburg Manufacturer FLENDER-GRAFFENSTADEN  
 Site Khursaniyah Al Fadhli Model No. TX40/5C  
 Unit STC-SV 06-3-A Serial No. \_\_\_\_\_  
 Service EM/CC Driver type electric motor  
 No. required 1 Driven equipment centrifugal compressor

**NOTE : Numbers within ( ) refer to applicable API standard 613 paragraphs**

Information To be completed by purchaser  Information to be completed by manufacturer

UNITS OF MEASUREMENT  BASIC GEAR DATA

US Customary units  
 SI units

RATING REQUIREMENTS

Driven equip. (2.1.4): Norm. \_\_\_\_\_ Max \_\_\_\_\_ kW  
 Driver: Rated \_\_\_\_\_ Max \_\_\_\_\_ kW  
 Normal transmitted power (2.2.2) \_\_\_\_\_ kW  
 Gear unit rated power (2.2.1) 1620 kW  
 Torque @ max cont speed \_\_\_\_\_ Nm  
 Max torque (2.2.1) \_\_\_\_\_ Nm @ \_\_\_\_\_ rpm  
 Reducer  Increaser  
 Rated speed (2.1.5):  
 Input 1800 rpm  Specified  Nominal  
 Output 10736 rpm  Specified  Nominal  
 Allow var in gear ratio (2.1.5) (+) (-) \_\_\_\_\_ %  
 Max continuous speed (1.5) 1800 / 10736 rpm  
 Trip speed (1.5) (2.1.7) 1980 / 11809,6 rpm  
 Gear service factor (2.2.3.1) 1,4 API 613/2003 5 TH (min)  
 Hardness (2.2.3.2) Pinion \_\_\_\_\_ Gear \_\_\_\_\_  
 Shaft assembly designation (2.1.10) L/R  
 HS shaft rot fac'g cpl'g (2.1.20.2)  CW  CCW  
 LS shaft rot fac'g cpl'g (2.1.20.2)  CW  CCW  
 External loads (2.1.16) \_\_\_\_\_  
 Other operating conditions (2.2.2) (2.6.1.3) \_\_\_\_\_

INSTALLATION DATA (2.1.14)

Indoor  Heated  Under roof  
 Outdoor  Unheated  Partial sides  
 Grade  Mezzanine  **ONSHORE**  
 Winterization required  Tropicalization required

Electrical area (2.1.10) Class \_\_\_\_\_ Grp \_\_\_\_\_ Div \_\_\_\_\_  
 Electrical area (2.1.10) Zone 2 Grp IIA Temp T1 °C  
 Max allow SPL (2.1.6) \_\_\_\_\_ dB(A) @ \_\_\_\_\_ m  
 Elevation \_\_\_\_\_ m Barometer \_\_\_\_\_ kPa abs  
 Range of ambient temperatures:  
 Dry bulb \_\_\_\_\_ °C Wet bulb \_\_\_\_\_ °C  
 Normal \_\_\_\_\_ °C  
 Maximum 82 °C  
 Minimum 0 °C  
 Unusual conditions  Dust  Fumes  
 \_\_\_\_\_

Single stage  Single helical  
 Double stage  Double helical  
 Epicyclic  horizontal offset

Mechanical rating (1.5.16) 2268 kW @ 1800 / 10737,9 rpm  
 Gear service factor (2.2.3.1) 1,46 API 613/2003 5 TH (actual)  
 Full load gear unit power loss 21 kW  
 Gear Unit Mechanical efficiency 98,70 %  
 Rating speed Pinion 10.737,9 Gear 1.800,0 rpm  
 Hardness used for  
 Rating, (HB or Rc) Pinion 58 HRC Gear 58 HRC  
 Tooth pitting index, "K" (2.2.4.1) (2.2.4.2)  
 Allowable 2,17 Actual 2,06 MPa  
 Material index number (Fig 3, Table 4) 3,03 MPa  
 Bending stress number, "S<sub>b</sub>" (2.2.5.1) (2.2.5.2)  
 Pinion: Allowable 265,4 Actual 251,0 MPa  
 Gear: Allowable 265,4 Actual 238,8 MPa  
 Pitch line velocity 63,0 m/s  
 Anticipated SPL (2.1.6) 82 dB(A) @ 1 m  
 WR<sup>2</sup> referred to LS shaft 20,88 kgm<sup>2</sup>  
 Breakaway torque 90 Nm @ LS Shaft  
 Pinion teeth hardness range 58 - 63 HRC  
 Pinion teeth hardening method CARBURIZED  
 HS shaft separate hardness range \_\_\_\_\_  
 Gear teeth (rim) hardness range 58 - 63 HRC  
 Gear teeth hardening method CARBURIZED  
 Gear hub:  
 Forged cylinder  Forged & Copped  Fabricated  
 Gear to Shaft fit method (2.5.3.2)  
 Integral  Keyed interference  Keyless interference  
 Rim attachment (2.5.3.2) FORGED GEAR WHEEL  
 LS shaft hardness range HB 230 - 274  
 Journal static weight loads (2.6.6.3)  
 Pinion 37 / 4 kg Gear 347 / 253 kg  
 Total gear unit assembled weight 1900 kg  
 NOTES: \_\_\_\_\_  
 \_\_\_\_\_  
 \_\_\_\_\_

**SPECIAL PURPOSE GEAR UNITS**  
**API 613 FIFTH EDITION**  
**DATA SHEET SI UNITS**

Job No. 41104 Item No. B  
P.O. No. \_\_\_\_\_ Date \_\_\_\_\_  
Requisition No. \_\_\_\_\_  
Inquiry No. \_\_\_\_\_  
Revision 1 Date 06.03.2015 By \_\_\_\_\_ HNI

■ GEAR DATA			
	Pinion	Gear	
Number of teeth	<u>29</u>	<u>173</u>	
Gear ratio	<u>5,97</u>		
Tangential load, "Wt" (2.2.4.2)	<u>25.731</u>		N
AGMA Geometry factor "J"	<u>0,52</u>	<u>0,54</u>	
Pitch diameter	<u>111,98</u>	<u>668,02</u>	mm
Outside diameter	<u>120,30</u>	<u>673,50</u>	mm
Root diameter	<u>103,05</u>	<u>656,32</u>	mm
Center groove diameter	<u>93,00</u>	<u>640,00</u>	mm
Normal pressure angle	<u>20,00</u>		deg
Normal diametral pitch	<u>7,26</u>		in <sup>-1</sup>
Helix angle	<u>24,25</u>		deg
Center distance	<u>390,00</u>		mm
Backlash min	<u>0,28</u>		mm
Net face width, "Fw"	<u>130,00</u>		mm
Pinion L/D	<u>1,74</u>		
Face overlap ratio	<u>4,86</u>		
Transverse contact ratio	<u>1,45</u>		
AGMA 6011 service factor	<u>2,87</u>		
Rating based on ANSI/AGMA 6011 with SF=1.0			
Durability Power	<u>5404</u>		kW
Strength Power	<u>4652</u>		kW
Tooth Surface Finish, Ra	<u>0,4</u>	<u>0,4</u>	µm
Tooth Generation Process	<u>Hobbing</u>	<u>Hobbing</u>	
Tooth Finishing Process	<u>Grinding</u>	<u>Grinding</u>	
Lead modification (2.2.4.6)	<input checked="" type="radio"/> Not Req'd	<input type="radio"/> Req'd	
Calculated Total Lead Mismatch			µm
■ SCUFFING DATA (2.2.6)			
Scuffing Data per ANSI/AGMA 925-A03			
Scuffing Risk (2.2.6) <=5% (Low)	Calculation Method	<u>AGMA925</u>	
Composite surface roughness, ox	<u>0,57</u>	µm	
Specific film thickness, EHL Amin	<u>2,54</u>	µm	
Tooth temperature, θm	<u>80</u>	°C	
Maximum contact temperature, θBmax	<u>93</u>	°C	
■ MATERIALS			
Gear casing	<u>Steel</u>	Oil seals	<u>aluminium</u>
Pinion(s)	<u>18CrNiMo7-6</u>		
Gear rim(s)	<u>18CrNiMo7-6</u>		
HS Shaft	<u>Integral</u>	LS Shaft	<u>42CrMo4</u>
Redial bearings	<u>Babbitt</u>	Backing	<u>Steel</u>
Thrust bearing(s)	<u>Babbitt</u>	Backing	<u>Steel</u>
○ SHAFT END DETAIL			
<input checked="" type="checkbox"/> Gear shaft end for coupling integral flange (2.5.4.2)			
<input checked="" type="checkbox"/> Pinion shaft end for coupling integral flange (2.5.4.2)			
<input checked="" type="checkbox"/> Other :	<u>WITHOUT BOLTS</u>		

○ COUPLINGS AND GUARDS					
	Pinion	Gear			
Coupling furnished by (3.2.1)	<u>Compr. Supplier</u>	<u>Compr. Supplier</u>			
Mount coupling halves (3.2.2)	<u>Compr. Supplier</u>	<u>Compr. Supplier</u>			
Cplg. guard adapter by (3.2.3)	<u>Gear Supplier</u>	<u>Gear Supplier</u>			
Cplg. guard furnished by (3.2.3)	<u>Compr. Supplier</u>	<u>Compr. Supplier</u>			
Coupling vendor (3.2.3)					
Vendor's model number (3.2.3)					
Coupling weight on shaft, kg	<u>10,4</u>	<u>26,4</u>			
CG inboard / outboard of shaft end	<u>Outboard</u>	<u>Outboard</u>			
Hub drill template provided	<input type="checkbox"/>	<input type="checkbox"/>			
■ SHAFT END DETAIL (2.5.4.2)					
Shaft end detail specified by: <input checked="" type="radio"/> Purchaser <input type="radio"/> Gear vendor					
(Integral unless otherwise specified)					
Shaft end detail if 'otherwise' specified:					
	Pinion	Gear			
Tapered / Keyless	<input type="radio"/> <input type="checkbox"/>	<input type="radio"/> <input type="checkbox"/>			
Tapered / 1-Key	<input type="radio"/> <input type="checkbox"/>	<input type="radio"/> <input type="checkbox"/>			
Tapered / 2-Keys	<input type="radio"/> <input type="checkbox"/>	<input type="radio"/> <input type="checkbox"/>			
Cylindrical / 1-Key	<input type="radio"/> <input type="checkbox"/>	<input type="radio"/> <input type="checkbox"/>			
Cylindrical / 2-Keys	<input type="radio"/> <input type="checkbox"/>	<input type="radio"/> <input type="checkbox"/>			
Other <u>Flanged</u>	<input checked="" type="radio"/> <input type="checkbox"/>	<input checked="" type="radio"/> <input type="checkbox"/>			
Shaft diameter	<u>75,0</u>	<u>120,0</u>	mm		
(If integral flange use diameter immediately adjacent to flange)					
■ RADIAL BEARINGS					
	Pinion		Gear		
Type	TPADS /	TPADS	CYL. /	CYL.	
Diameter	<u>80</u> /	<u>80</u>	<u>120</u> /	<u>120</u>	mm
Length	<u>56</u> /	<u>56</u>	<u>60</u> /	<u>60</u>	mm
Journal velocity	<u>45,0</u> /	<u>45,0</u>	<u>11,3</u> /	<u>11,3</u>	m/s
Loading	<u>3,08</u> /	<u>3,10</u>	<u>2,52</u> /	<u>2,26</u>	N/mm <sup>2</sup>
Clearance (min-max)					mm
Span	<u>340</u>		<u>340</u>		mm
Power loss each bearing	<u>6,3</u> /	<u>6,3</u>	<u>0,7</u> /	<u>0,7</u>	kW
Oil flow each bearing	<u>15,0</u> /	<u>15,0</u>	<u>5,0</u> /	<u>5,0</u>	l/min
■ THRUST BEARINGS					
Location	<u>OPP.CPLG.SIDE</u>				
Manufacturer	<u>FLENDER</u>	<u>FLENDER</u>			
Type	<u>NO</u>		<u>COMB.TAP.LANDS</u>		
Size			<u>BPK LEG 4"</u>		
Area			<u>5160</u> mm <sup>2</sup>		
Loading			<u>1,35</u> MPa		
Rating			<u>1,50</u> MPa		
Int. thrust load			N		
Ext. thrust load	<u>2.700</u>	<u>4.250</u>	N		
Power loss each	<u>0,0</u>	<u>5,0</u>	kW		
Oil flow each bearing	<u>0,0</u>	<u>15,0</u>	l/min		
NOTES :					

**SPECIAL PURPOSE GEAR UNITS**  
**API 613 FIFTH EDITION**  
**DATA SHEET SI UNITS**

Job No. 41104 Item No. B  
 P.O. No. \_\_\_\_\_ Date \_\_\_\_\_  
 Requisition No. \_\_\_\_\_  
 Inquiry No. \_\_\_\_\_  
 Revision 1 Date 06.03.2015 By HNI

1 **○ LUBRICATION REQUIREMENTS**

2  Oil system furnished by (2.8.3) \_\_\_\_\_

3  Other \_\_\_\_\_  Gear vendor \_\_\_\_\_

4  Oil visc. \_\_\_\_\_ cp @ 40°C \_\_\_\_\_ cp @ 100°C (2.8.6)

5  ISO Grade \_\_\_\_\_ Load stage (2.2.6) 7,0

6

7 **■ MESH**

8 Mesh and windage power loss 2,0 KW

9 Oil flow, mesh 9,0 l/min

10

11 **■ LUBRICATION REQUIREMENTS**

12 Min. start-up oil temperature 20,0 °C

13 Normal oil inlet temperature 60,0 °C

14 Maximum oil inlet temperature 65,0 °C

15 Unit oil flow (total) 64,0 l/min

16 Unit oil pressure 2,5 bar

17  Oil visc. \_\_\_\_\_ cp @ 40°C \_\_\_\_\_ cp @ 100°C (2.8.6)

18  ISO Grade 46 Load stage (2.2.6) 7,0

19

20 **■ PIPING CONNECTIONS**

Service	No.	Size	Type
Lube oil inlet	1	1,5 in.	ANSI 150 LBS
Lube oil outlet	1	6 in.	ANSI 150 LBS
Casing drain *			
Vent	1	1,5 in.	ANSI 150 LBS
Casing purge			

27 \* Casing drain is 'dead bottom' housing drain, not lube oil outlet

28 **○ MOUNTING PLATES**

29  Gear furnished with (3.3.1.1)

30  Baseplate  Soleplate  Subplate(s) (3.3.2.10)

31  Mounting plates(s) furnished by (3.3.1.1) \_\_\_\_\_

32  Baseplate leveling (3.3.2.3) \_\_\_\_\_

33  Baseplate with leveling pads (3.3.2.3)

34  Baseplate suitable for column mounting (3.3.2.4)

35  Vendor review of purchaser's foundation dwgs. (2.1.13)

36  Grout type (3.3.1.2.4) \_\_\_\_\_

37

38 **○ CONTRACT DATA**

39  Test data prior to shipment \_\_\_\_\_

40  Progress report (5.3.3) \_\_\_\_\_

41  Vendor sign-off of inspector checklist (4.1.1.3)

42  Information retained for 20 years (4.2.1.1) (4.2.2.6.1)

43  Technical manual (5.3.6.4)

44  PAINTING (4.4.3.1)  Flender standard RAL5015 (blue)

45  Painting housing interior not allowed (2.3.1.14)

46 **○ SHIPMENT**

47  Steel rotor storage container (4.4.5)  Shaft covers (4.4.4)

	Contract unit	Spares
Export boxing	<input type="checkbox"/>	<input type="checkbox"/>
Domestic boxing	<input type="checkbox"/>	<input type="checkbox"/>
Outdoor storage over 6 mos.	<input type="checkbox"/>	3 years indoor <input type="checkbox"/> (4.4.3.9)

1 **○ ADDITIONAL REQUIREMENTS**

2 **○ VIBRATION DETECTORS**

**RADIAL (3.4.2.1) (2.7.4.5) (2.7.4.6)**

Manufacturer BENTLY NEVADA  Total No. 8

X-Y probes pinion bearings  Coupling end  Blind end

X-Y probes gear bearings  Coupling end  Blind end

Other \_\_\_\_\_

**AXIAL (3.4.2.1) (2.7.4.5) (2.7.4.6)**

Manufacturer BENTLY NEVADA  Total No. 2

Dual probes at each thrust bearing

Single probe any shaft without thrust bearing

Other \_\_\_\_\_

**ONE EVENT PER REVOLUTION PROBE (2.7.4.5) (2.7.4.6)**

Manufacturer BENTLY NEVADA Total No. 2

One on input shaft  One on output shaft

Other \_\_\_\_\_

**ACCELEROMETER (3.4.2.1) (2.7.4.5) (2.7.4.6)**

Manufacturer BENTLY NEVADA  No. required 2

Pinion coupling end  Gear coupling end

Other \_\_\_\_\_

11 **○ TEMPERATURE DETECTORS**

Dial type thermometers (3.4.2.7) \_\_\_\_\_

Type brg. temp. sensors (3.4.2.7) (2.7.1.3) PT100

RTD  Thermocouple /  Simplex  Duplex

Calibration Yes

HSALS bearings no. sensors each 2 / 2

Thrust number of sensing elements each face 2

12 **○ OTHER VIBRATION AND TEMPERATURE**

(3.4.2.5) (3.4.2.6) Other Gear vendor

Oscillator demodulator supplied by

Vibration monitor supplied by

Vibration shutdown delay time \_\_\_\_\_ seconds

Temperature monitor supplied by

Oscillator demodulator J-box by

Temp. sensor termination J-box by

J-box type \_\_\_\_\_ Mount \_\_\_\_\_

13 **○ MISCELLANEOUS**

Undamped critical analysis report (2.6.2.1)

w/ dampd rotor respns anlysis rpt (2.6.2.4.3) (2.6.2.6)

Torsional analysis by (2.6.5.2)  Gear vendor  Other

Spare set of gear rotors (4.3.2.4)

Gear case furnished with inlet purge connection (2.4.3)

Orientation of oil inlet & drain conns. (2.4.6) \_\_\_\_\_

Filter breather location (2.3.1.12) Prov. on upper casing

Torsional device provisions (2.5.4.5) \_\_\_\_\_

Rotor vertical storage provisions (2.5.4.8) \_\_\_\_\_

Rotor vertical storage fixture(s) (3.6.2) \_\_\_\_\_

Vendor service rep. on site (2.1.13)

**SPECIAL PURPOSE GEAR UNITS**  
**API 613 FIFTH EDITION**  
**DATA SHEET SI UNITS**

Job No. 41104 Item No. B  
P.O. No. \_\_\_\_\_ Date \_\_\_\_\_  
Requisition No. \_\_\_\_\_  
Inquiry No. \_\_\_\_\_  
Revision 1 Date 06.03.2015 By HNI

O INSPECTIONS AND TESTS (4.1)				
<input type="checkbox"/> Advance notice of witness testing required (4.1.3)				
Number calendar days _____				
	Req'd	Witness	Observe	Test Log
6	Shop Inspection (4.1.1)	<input type="checkbox"/>	<input type="checkbox"/>	<input type="checkbox"/>
7	Cleanliness Inspection (4.2.3.1)	<input type="checkbox"/>	<input type="checkbox"/>	<input type="checkbox"/>
8	Hardness Verification (4.2.3.3)	<input checked="" type="checkbox"/>	<input type="checkbox"/>	<input checked="" type="checkbox"/>
9	Dismantle-reassembly (4.3.2.3.1)	<input checked="" type="checkbox"/>	<input type="checkbox"/>	<input type="checkbox"/>
10	Contact Check (2.5.2.2)	<input checked="" type="checkbox"/>	<input type="checkbox"/>	<input type="checkbox"/>
11	Contact Check Tape Lift (2.5.2.2)	<input checked="" type="checkbox"/>	<input type="checkbox"/>	<input checked="" type="checkbox"/>
12	Gear accuracy check (2.5.2.1)	<input checked="" type="checkbox"/>	<input type="checkbox"/>	<input type="checkbox"/>
13	Double helical axial stability (2.5.2.3)	<input checked="" type="checkbox"/>	<input type="checkbox"/>	<input checked="" type="checkbox"/>
14	Special testing integral forged gears (2.5.3.3)			
15	(testing per mutual agreement)	<input type="checkbox"/>	<input type="checkbox"/>	<input type="checkbox"/>
16	Residual unbalance check (2.6.6.2)	<input checked="" type="checkbox"/>	<input type="checkbox"/>	<input checked="" type="checkbox"/>
17	Mechanical Run Test (Main) (4.3.2)	<input checked="" type="checkbox"/>	<input type="checkbox"/>	<input checked="" type="checkbox"/>
18	Mechanical Run Test (Spare) (4.3.2.4)	<input type="checkbox"/>	<input type="checkbox"/>	<input type="checkbox"/>
19	Add'l. Mechanical Tests (4.3.2.2.16)	<input type="checkbox"/>	<input type="checkbox"/>	<input type="checkbox"/>
20	Part or Full Load And Full Speed			
21	Test (4.3.3.1)	<input type="checkbox"/>	<input type="checkbox"/>	<input type="checkbox"/>
22	Full torque, reduced speed (4.3.3.2)	<input type="checkbox"/>	<input type="checkbox"/>	<input type="checkbox"/>
23	Full Torque Static Test (4.3.3.3)	<input type="checkbox"/>	<input type="checkbox"/>	<input type="checkbox"/>
24	Back-To-Back Locked Torque			
25	Test (4.3.3.4)	<input type="checkbox"/>	<input type="checkbox"/>	<input type="checkbox"/>
26	Sound Level Test (4.3.3.5)	<input checked="" type="checkbox"/>	<input type="checkbox"/>	<input checked="" type="checkbox"/>
27	Additional gear tooth test (4.2.2.8)	<input type="checkbox"/>	<input type="checkbox"/>	<input type="checkbox"/>
28	Use shop Lube System	<input checked="" type="checkbox"/>	<input type="checkbox"/>	<input type="checkbox"/>
29	Use job lube system	<input type="checkbox"/>	<input type="checkbox"/>	<input type="checkbox"/>
30	Use shop Vibration Probes, Etc.	<input type="checkbox"/>	<input type="checkbox"/>	<input type="checkbox"/>
31	Use job Vibration Probes, Etc.	<input checked="" type="checkbox"/>	<input type="checkbox"/>	<input type="checkbox"/>
32	Final Assembly, Maintenance &			
33	Running Clearance (4.2.1.1.e)	<input checked="" type="checkbox"/>	<input type="checkbox"/>	<input checked="" type="checkbox"/>
34	Oil System Cleanliness (4.2.3.2)	<input type="checkbox"/>	<input type="checkbox"/>	<input type="checkbox"/>
35	Oil System-Casing Joint			
36	Tightness (4.3.2.1.4)	<input type="checkbox"/>	<input type="checkbox"/>	<input type="checkbox"/>
37	Warning And Protection			
38	Devices (4.3.2.1.5)	<input type="checkbox"/>	<input type="checkbox"/>	<input type="checkbox"/>
39	Seismic Vibration Data (4.3.2.2.3)	<input type="checkbox"/>	<input type="checkbox"/>	<input type="checkbox"/>
40	Vibration, Phase Plots (4.3.2.2.12)	<input checked="" type="checkbox"/>	<input type="checkbox"/>	<input checked="" type="checkbox"/>
41	Oil Inlet Range test (4.3.2.2.13)	<input type="checkbox"/>	<input type="checkbox"/>	<input type="checkbox"/>
42	Tape recorded Vibration Data	<input checked="" type="checkbox"/>	<input type="checkbox"/>	<input checked="" type="checkbox"/>
43	(4.3.2.2.14) (4.3.2.2.15)	<input type="checkbox"/>	<input type="checkbox"/>	<input type="checkbox"/>
44	NON-DESTRUCTIVE TESTING (4.2.1.2) (4.2.2.1)			
45		Surface	Sub surface	Log
46	<input type="checkbox"/> Casing	<input type="checkbox"/>	<input type="checkbox"/>	<input type="checkbox"/>
47	<input checked="" type="checkbox"/> Rot. Elmts.	<input checked="" type="checkbox"/>	<input checked="" type="checkbox"/>	<input checked="" type="checkbox"/>
48	<input checked="" type="checkbox"/> Bearings	<input checked="" type="checkbox"/>	<input checked="" type="checkbox"/>	<input checked="" type="checkbox"/>
49	<input type="checkbox"/> Other :	<input type="checkbox"/>	<input type="checkbox"/>	<input type="checkbox"/>
50	(Specify)			

NOTES : \_\_\_\_\_

During start-up, gears can exhibit a transient spike reading of vibration levels that will exceed shutdown settings. Therefore a trip multiplier is recommended in the control system.

Mechanical running test duration 4 hours including

- Shaft vibration record using job vibration probes if ordered
- Bearings temperature records
- Casing vibration measurement
- Sound level pressure measurement
- Power losses measurement at oil outlet
- Performed with oil ISO VG 32

Oil flow requirement and power losses are calculated values only, add normal safety margins for sizing heat exchangers.

**PRELIMINARY MASS ELASTIC DATA**

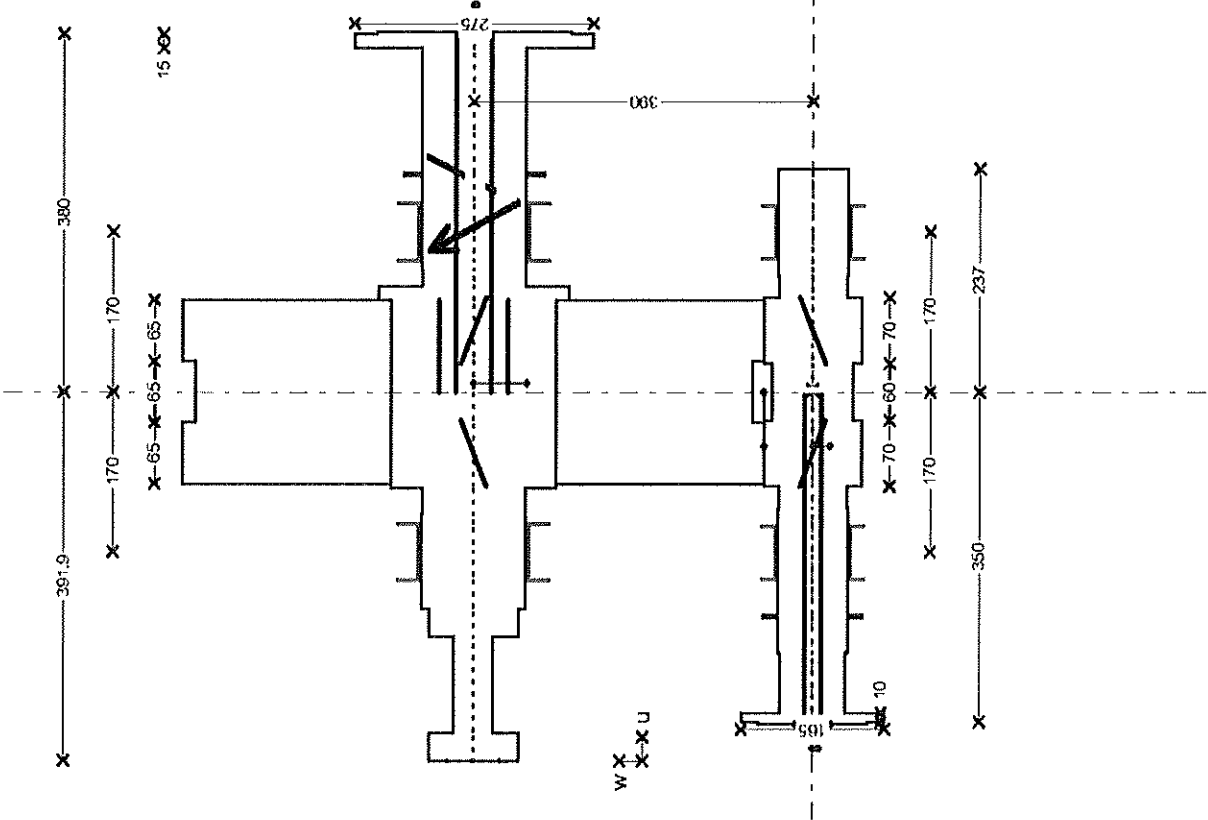

Customer : Siemens AG Duisburg  
 Destination : Khursaniyah Al Fadhihi  
 Purchaser order :  
 F-G job number : D 4:10481 OL  
 Type and serial N° : TX40/5C

Power rating : 1620 kW  
 Service factor : AP1613.03 >=1,4  
 Input speed : 1800 rpm  
 Output speed : 10737,9 rpm  
 Speed ratio : 5,96

Weight HSS : 30,5 kg  
 Weight pos. from teeth middle HSS : 57,5 mm  
 Inertia HSS : 0,038 Kg.m²  
 Stiffness HSS : 1,11 MN/mrd  
 Bearing type 1 : Tilting pads 80 x 56  
 Bearing type 2 : Tilting pads 80 x 56  
 Add. weight on brg. side 1 : 10,4 kg

Weight LSS : 574,3 kg  
 Weight pos. from teeth middle LSS : 9 mm  
 Inertia LSS : 28,526 Kg.m²  
 Stiffness LSS : 6,5 MN/mrd  
 Bearing type 4 : Cylindrical 120 x 60  
 Bearing type 3 : Cylindrical 120 x 60  
 Add. weight on brg. side 4 : 26,4 kg



Positive direction of external

APPAREIL.xls \_ Edition du :06.03.2015  
 1/1



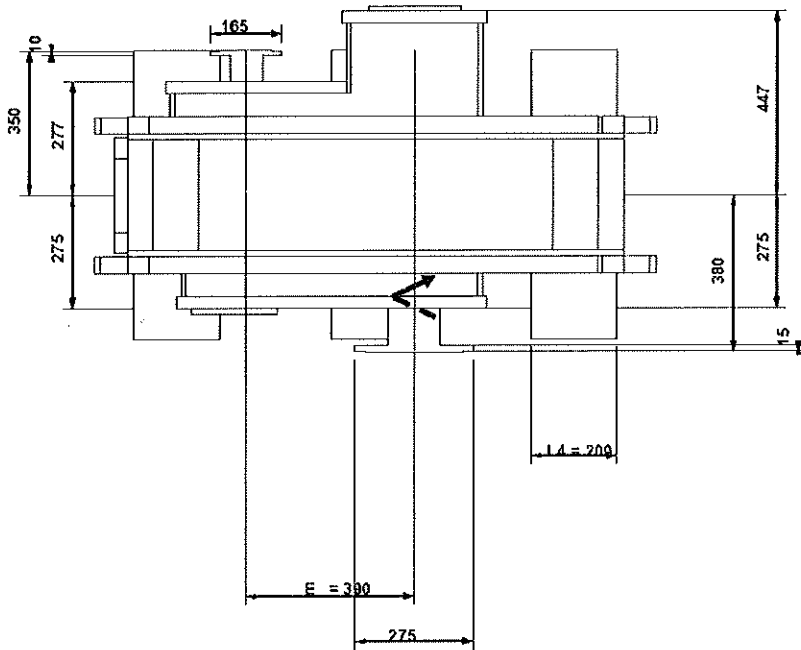
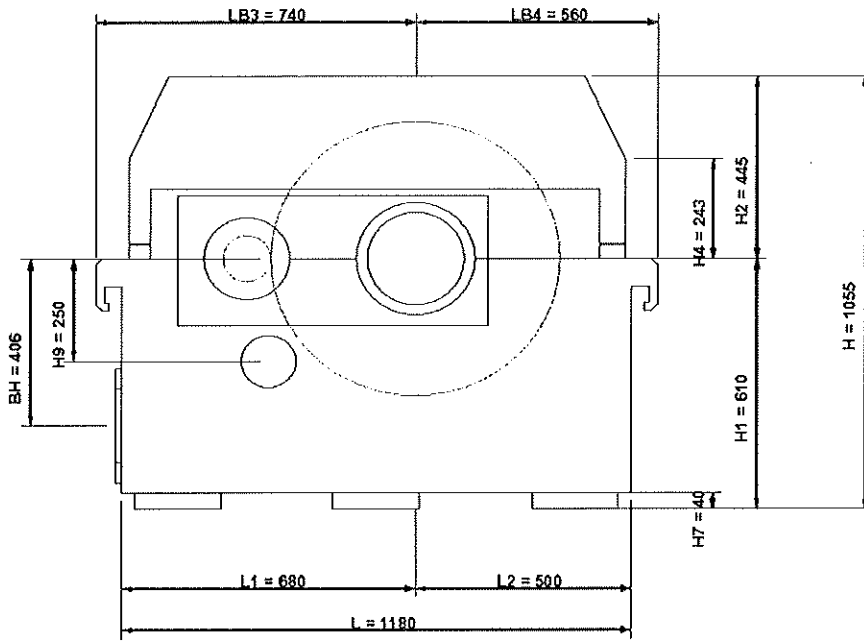

<b>ADDITIONAL TECHNICAL DATASHEET</b>		Job No. <u>41104</u> Item No. <u>B</u>																																			
		P. O. No. _____ Date _____																																			
		Requisition No. _____																																			
		Inquiry No. _____																																			
		Revision <u>1</u> Date <u>06.03.2015</u> By <u>HNI</u>																																			
<input checked="" type="checkbox"/> <b>ADDITIONAL GEAR DATA</b>		<input type="checkbox"/> <b>TURNING GEAR (Dimensioning is preliminary I)</b>																																			
<i>Efficiency</i>		<i>Calculation results</i>																																			
<table border="1" style="width:100%; border-collapse: collapse;"> <thead> <tr> <th>Percent of rated power</th> <th>Efficiency</th> </tr> </thead> <tbody> <tr> <td>100%</td> <td style="text-align: center;"><b>98,70</b></td> </tr> <tr> <td>75%</td> <td style="text-align: center;"><b>98,66</b></td> </tr> <tr> <td>50%</td> <td style="text-align: center;"><b>98,38</b></td> </tr> <tr> <td>25%</td> <td style="text-align: center;"><b>97,42</b></td> </tr> <tr> <td>10%</td> <td style="text-align: center;"><b>87,68</b></td> </tr> </tbody> </table>		Percent of rated power	Efficiency	100%	<b>98,70</b>	75%	<b>98,66</b>	50%	<b>98,38</b>	25%	<b>97,42</b>	10%	<b>87,68</b>	Required turning speed _____ rpm Actual turning speed _____ rpm Required breakaway torque _____ Nm Actual breakaway torque _____ Nm Actual maximum torque _____ Nm Actual acceleration time _____ s																							
Percent of rated power	Efficiency																																				
100%	<b>98,70</b>																																				
75%	<b>98,66</b>																																				
50%	<b>98,38</b>																																				
25%	<b>97,42</b>																																				
10%	<b>87,68</b>																																				
<i>Losses</i>		<i>Motor</i>																																			
Power loss at no load _____ kW Heat rejection _____ kcal/h		Supplier _____ Power _____ kW Voltage _____ V Frequency _____ Hz Speed _____ rpm Electric standard _____																																			
<input type="checkbox"/> <b>PUMP DETAILS (Dimensioning is preliminary I)</b>		<i>Turning gear</i>																																			
Design : _____ Speed : _____ rpm Oil flow : _____ l/min Oil pressure : _____ bar NPSH : _____ m Safety valve : _____ Driving method : _____ Material : _____ Flanges : _____ Testing : _____ Furniture of ATEX certificate : _____		Type _____ Ratio _____																																			
		<i>Clutch</i>																																			
		Type _____ Max. allowable torque _____ Nm																																			
		<i>Miscellaneous</i>																																			
		Starting device _____ Switch details _____																																			
<input checked="" type="checkbox"/> <b>INSTRUMENTATION PACKAGE</b>																																					
<i>Thermometer</i>		<i>Thermoelements</i>																																			
<table border="1" style="width:100%; border-collapse: collapse;"> <thead> <tr> <th></th> <th>Bearing</th> <th>Thrust bearing</th> <th>Oil inlet/outlet</th> </tr> </thead> <tbody> <tr> <td>Qty</td> <td></td> <td></td> <td></td> </tr> <tr> <td>Type</td> <td></td> <td></td> <td></td> </tr> </tbody> </table>			Bearing	Thrust bearing	Oil inlet/outlet	Qty				Type				<table border="1" style="width:100%; border-collapse: collapse;"> <thead> <tr> <th></th> <th>Bearing</th> <th>Thrust bearing</th> <th>Oil inlet/outlet</th> </tr> </thead> <tbody> <tr> <td>Type</td> <td>DUPLEX 2x3F</td> <td>DUPLEX 2x3F</td> <td></td> </tr> <tr> <td>Classification</td> <td>IEC60751</td> <td>IEC60751</td> <td></td> </tr> <tr> <td>Removable from the outside</td> <td>NO</td> <td>NO</td> <td></td> </tr> <tr> <td>ATEX</td> <td>ATEX Eexia</td> <td>ATEX Eexia</td> <td></td> </tr> </tbody> </table>		Bearing	Thrust bearing	Oil inlet/outlet	Type	DUPLEX 2x3F	DUPLEX 2x3F		Classification	IEC60751	IEC60751		Removable from the outside	NO	NO		ATEX	ATEX Eexia	ATEX Eexia				
	Bearing	Thrust bearing	Oil inlet/outlet																																		
Qty																																					
Type																																					
	Bearing	Thrust bearing	Oil inlet/outlet																																		
Type	DUPLEX 2x3F	DUPLEX 2x3F																																			
Classification	IEC60751	IEC60751																																			
Removable from the outside	NO	NO																																			
ATEX	ATEX Eexia	ATEX Eexia																																			
<i>Shaft vibrations</i>																																					
<table border="1" style="width:100%; border-collapse: collapse;"> <thead> <tr> <th></th> <th>Radial</th> <th>Axial</th> <th>Keyphasor</th> <th>Accelerometer</th> </tr> </thead> <tbody> <tr> <td>Type</td> <td>B.N. 3300 XL 8mm Sys. 9M</td> <td>HS No LS BENTLY NEVADA 3300 XL 8mm Sys. 9M</td> <td>B.N. 3300 XL 8mm Sys. 9M</td> <td>ACCELEROMETER BENTLY</td> </tr> <tr> <td>Probe</td> <td>Yes</td> <td>HS No LS Yes</td> <td>Yes</td> <td></td> </tr> <tr> <td>Proximitior</td> <td>Yes</td> <td>HS No LS Yes</td> <td>Yes</td> <td style="background-color: #cccccc;"></td> </tr> <tr> <td>Probe holder</td> <td>Yes</td> <td>HS No LS Yes</td> <td>Yes</td> <td style="background-color: #cccccc;"></td> </tr> <tr> <td>Connection head</td> <td>Yes</td> <td>HS No LS Yes</td> <td>Yes</td> <td style="background-color: #cccccc;"></td> </tr> <tr> <td>mounting kit</td> <td style="background-color: #cccccc;"></td> <td style="background-color: #cccccc;"></td> <td style="background-color: #cccccc;"></td> <td>Yes</td> </tr> </tbody> </table>				Radial	Axial	Keyphasor	Accelerometer	Type	B.N. 3300 XL 8mm Sys. 9M	HS No LS BENTLY NEVADA 3300 XL 8mm Sys. 9M	B.N. 3300 XL 8mm Sys. 9M	ACCELEROMETER BENTLY	Probe	Yes	HS No LS Yes	Yes		Proximitior	Yes	HS No LS Yes	Yes		Probe holder	Yes	HS No LS Yes	Yes		Connection head	Yes	HS No LS Yes	Yes		mounting kit				Yes
	Radial	Axial	Keyphasor	Accelerometer																																	
Type	B.N. 3300 XL 8mm Sys. 9M	HS No LS BENTLY NEVADA 3300 XL 8mm Sys. 9M	B.N. 3300 XL 8mm Sys. 9M	ACCELEROMETER BENTLY																																	
Probe	Yes	HS No LS Yes	Yes																																		
Proximitior	Yes	HS No LS Yes	Yes																																		
Probe holder	Yes	HS No LS Yes	Yes																																		
Connection head	Yes	HS No LS Yes	Yes																																		
mounting kit				Yes																																	
<i>Junction box(es)</i>		<i>Miscellaneous</i>																																			
Qty _____ 0 Manufacturer _____ Material _____ ATEX _____ None		Identification <input checked="" type="checkbox"/> wire <input checked="" type="checkbox"/> conduit <input type="checkbox"/> junction box Conduit type _____ Transmitter type _____ Qty _____ Terminal block type _____ Qty _____																																			

### **Commercial Conditions**

- Prices are quoted FCA Illkirch-Graffenstaden following Incoterms 2010 including packing cat 1A of SEI, 1999 issue, ind. 2.
- Progress payments : 100% at delivery.
- This quotation is subjected to the Flender Graffenstaden Standard Terms and Conditions of Sales and valid for acceptance until the 15<sup>th</sup> of July 2015.
- Where approval of drawings is required, approval must be in line with the document schedule.
- Warranty period is 18 months of operation or 24 months after delivery whichever occurs first. We recommend the supervision of our engineer for the commissioning.
- Flender-Graffenstaden SAS shall not be obligated to fulfill this agreement if such fulfillment is prevented by any impediments arising out of national or international foreign trade or customs requirements or any embargoes or other sanctions.

### **Applicable documents for the quotation (available on demands)**

Documents schedule,  
Quality plan  
Painting standard,  
Standard Terms and Conditions of Sales

We thank you for the opportunity of quoting and look forward to the pleasure of serving you.

Very truly yours,

N. HOST  
(Project Engineer)



Y. FRIEDMANN  
(Sales Manager)



Generated with CAMEC V 4.9.5 26 Feb 2014

**\*\* "This quotation is subject to confidentiality. Information thereof may not be shared with or forwarded to any third parties!"**